

# INSTALLATION, OPERATION AND MAINTENANCE MANUAL

## 3” and 4” Figure 983-D Combination Air Valve with Surge Check (Anti-Slam Device)

SECTION 1 – Figure 983-D Combination Air Valves with Surge Check  
Instructions

SECTION 2 – Figure 930 Air & Vacuum Valve Instructions

SECTION 3 – Figure 905 Air Release Valve Instructions

SECTION 4 – Figure F284-D Surge Check Instructions



234 Clay Avenue • Mars, PA 16046 USA  
Telephone (724) 776-1020 • Fax (724) 776-1254  
E-mail: [info-ga@vag-group.com](mailto:info-ga@vag-group.com)

Manual Number IOM 983.01 3&4inch 082622



WARNING: Cancer and Reproductive Harm – [www.Prop65Warnings.ca.gov](http://www.Prop65Warnings.ca.gov)

# Section 1

# INSTALLATION, OPERATION AND MAINTENANCE MANUAL

## 3” and 4” Figure 983-D Combination Air Valve with Surge Check (Anti-Slam Device)

### TABLE OF CONTENTS

Introduction.....	1
Description of Operation .....	1
Receiving & Storage.....	1
Installation.....	1
Start-Up.....	2
Preventative Maintenance .....	2
Testing .....	2
Trouble Shooting.....	2
Repair Instructions .....	2
Replacement Parts .....	2
Warranty.....	2
Assembly Drawing/Component Location ..	2



234 Clay Avenue • Mars, PA 16046 USA  
Telephone (724) 776-1020 • Fax (724) 776-1254  
E-mail: [info-ga@vag-group.com](mailto:info-ga@vag-group.com)

Manual Number IOM-983.01-3&4-082622



WARNING: Cancer and Reproductive Harm – [www.Prop65Warnings.ca.gov](http://www.Prop65Warnings.ca.gov)

# INSTALLATION, OPERATION and MAINTENANCE

## 3" and 4" Combination Air Valves with Surge Check

### INTRODUCTION

This manual provides information to install, operate and maintain GA Industries pilot-operated pressure reducing valves to ensure a long service life. The valve is ruggedly constructed to provide many decades of dependable service with minimal maintenance.

#### CAUTION

The valve is NOT recommended for use with toxic, corrosive, or flammable fluids.

The Shop Order (SO) Number, Figure Number, size, and pressure rating are stamped on a nameplate attached to the valve. Please refer to the SO number when ordering parts.

The Figure 983-D is suitable for use with finished water, raw water and treated effluent that is free of debris.

### DESCRIPTION OF OPERATION

The Figure 983-D consists of a Figure 930-D flanged air & vacuum valve, a Figure 905 air release valve and a Figure F284-D surge check, factory assembled and tested as a unit.

Refer to Page 2 for identification and location of the individual valves that comprise the assembly.

The valve is open when void of water. Air is discharged through the air vacuum valve's large orifice as the system is filled with water. An excessive air discharge rate closes the surge check to reduce the discharge area, slowing the air & vacuum valve closure to reduce slam and surge associated with a sudden air valve closure. After the air & vacuum valve is closed and the system is pressurized, any air that collects in the valve is automatically vented through the air release valve's small orifice. The air & vacuum valve re-opens to admit air when the system is drained, or a negative system pressure occurs.

### RECEIVING AND STORAGE

Inspect the valve upon receipt for damage during shipment. Carefully unload all valves to the ground without dropping.

Valves should remain in a clean, dry, and weather protected area until installed. After completion of shop testing the valve is drained of the test water but

a small residual amount could remain so the valve should be protected from freezing during storage.

### INSTALLATION

Figure Number 983-D has an ANSI Class 125 flanged pipeline connection. The standard valve has an NPT threaded outlet that can be piped to a drain.

The valve must be installed in a vertical orientation for it to properly function.

Prior to installation ensure all debris, packing material or other foreign material has been removed from both ports.

If installed outdoors, below ground in a vault or in an unheated area, adequate freeze protection must be provided.

Adequate isolating valves should be installed between the valve and the pipeline or system to facilitate maintenance. If a butterfly valve is used, be aware of the required disc clearance shown in the O & M for the Figure 284-D.

The valve should be installed with sufficient clearance to permit maintenance and removal of internal components.

The valve is not designed to support adjacent equipment, piping loads should not be imposed on the valve and large valves should be properly supported.

Flat-faced flanged valves should be mated with flat-faced flanges and full-face gaskets. If ring gaskets are used the bolt material shall be ASTM A307 Grade B (or equivalent). Higher strength bolting should only be used with full-face gaskets.

Lower heavy valves using slings or chains around the valve body and/or the lifting eyes. DO NOT LIFT BY THE EXTERNAL PIPING. Lubricate the bolts or studs and insert around flange. Lightly tighten bolts until gaps are eliminated. Torque bolts in an alternating pattern in graduated steps. If leakage occurs wait 24 hours and re-torque the bolts but do not compress the gasket more than 50% or exceed bolt maximum torque rating.

**START-UP**

The valve does not require any calibration or adjustment prior to putting it into service.

In rare situations, it may be necessary to “adjust” the surge check’s reduced area. If noted that the air & vacuum valve “slams” shut and/or there is a significant pressure surge when the valve closes, install a pipe plug in one of the tapped holes in the surge check disc. If this does not mitigate the slam/surge install another pipe plug. **DO NOT PLUG ALL THE HOLES.**

**PREVENTATIVE MAINTENANCE**

No routine lubrication or adjustments are needed. The valve should be visually to check for leaks. If leakage is detected, see **TROUBLESHOOTING** to resolve.

**WARNING**

Personal injury may occur if the valve is disassembled while pressurized. Before attempting disassembly, follow appropriate lockout/tag out procedures to prevent accidental pressurization.

**TESTING**

The valve can be tested to ensure it is in good working order.

1. Isolate the valve from the pipeline
2. Remove the pipe plug from the top of the Figure 905 to de-pressurize the assembly
3. Remove the pipe plug in the side of the Figure 930 just above the pipe flange
4. The float in the Figure 930 should fall as water leaves the valve
5. Replace the pipe plugs and slowly open the isolating valve
6. The Figure 930 float should rise and seal tightly while the Figure 905 may continue to release air for a while then close tightly.

**TROUBLESHOOTING**

SYMPTOM or PROBLEM	SOLUTION
<b>Leakage from outlet of Air &amp; Vacuum valve when closed</b>	
• Debris lodged between float and seat	Remove debris, inspect for damage
• Worn or damaged seat ring	Inspect, replace (See Figure 930 Repair Instructions)
• Deformed or damaged float	Inspect, replace (See Figure 930 Repair Instructions)
<b>Leakage from outlet of Air Release valve when closed</b>	
• Debris lodged between orifice and orifice button	Remove debris, inspect for damage
• Worn or damaged orifice or orifice button	Inspect, replace (See Figure 905 Repair Instructions)
• Deformed or damaged float	Inspect, replace (See Figure 905 Repair Instructions)

**REPAIR INSTRUCTIONS**

Refer to the instructions for the inspection, troubleshooting and repair of each of the valves used in the Figure 983-D assembly.

**REPLACEMENT PARTS**

Genuine replacement parts are available from your local GA Industries representative or from the factory:

VAG USA, LLC  
 234 Clay Avenue  
 Mars, PA 16046 USA  
 Telephone: 724-776-1020  
 Fax: 724-776-1254  
 E-mail: [quotes-ga@vag-group.com](mailto:quotes-ga@vag-group.com)

Please have the nameplate data available when ordering parts.

**WARRANTY:**

The Warranty for GA Industries valves is included in our Terms and Conditions which can be found here: <https://gaindustries.com/terms>

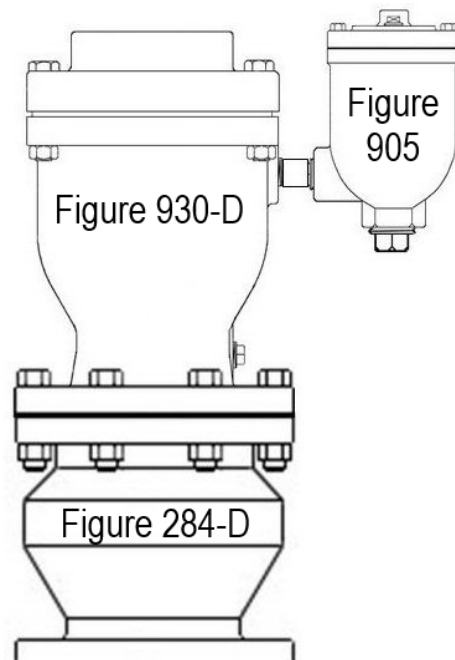

3" and 4" Figure 983-D

# Section 2

# INSTALLATION, OPERATION AND MAINTENANCE MANUAL

## Figures 930-T, 930-DT, 930-UT

**1/2" to 4" Air & Vacuum Valves  
for Clean Water**

**Drawings EAV-7051, EAV-7052, EAV-7053**



234 Clay Avenue • Mars, PA 16046 USA  
Telephone (724) 776-1020 • Fax (724) 776-1254  
E-mail: [info-ga@vag-group.com](mailto:info-ga@vag-group.com)

Manual Number 931.1-IOM 082622



WARNING: Cancer and Reproductive Harm – [www.Prop65Warnings.ca.gov](http://www.Prop65Warnings.ca.gov)

# INSTALLATION, OPERATION and MAINTENANCE

## Figure 930 Air & Vacuum Valves

### INTRODUCTION

This manual will provide the information to properly install, operate and maintain the valve to ensure a long service life. The Figure 930 Air & Vacuum Valve is ruggedly constructed to provide years of trouble-free operation with minimal maintenance.

These Air & Vacuum Valves are not intended for use with fluids containing suspended solids such as wastewater and sewage. The GA Industries Figure 935 or 939 Sewage Service Air & Vacuum Valves are recommended for such applications.

### CAUTION

The valve is NOT recommended for use with toxic fluids, fuels or fluids containing hazardous gases

The Shop Order (SO) Number, Figure Number, size and pressure rating are stamped on a nameplate attached to the valve. Please refer to the SO number when ordering parts.

### DESCRIPTION OF OPERATION

The Figure 930 allows air that is being pushed ahead of the incoming fluid to escape and ensure a complete filling of the pipeline or vessel. Once the air has been exhausted and the system is pressurized the valve closes tight. It does not re-open unless and until the system is drained and/or a negative pressure condition occurs within the pipe or vessel in order to admit air to minimize the vacuum condition.

The Figure 930 employs the Kinetic aerodynamic operating principle designed to ensure the valve is not prematurely blown shut by the high velocity exiting air.

### RECEIVING AND STORAGE

Inspect the valve upon receipt for damage during shipment. Carefully unload all valves to the ground without dropping. Do not pick up the valve by the "cowl."

The valves should remain in a clean, dry and weather protected area until installed. For long term storage (greater than 6 months) the rubber surfaces of the seat should be coated with a non-toxic lubricant such as "SuperLube" made by Synco Chemical. Do not expose the rubber parts to sunlight or ozone.

### INSTALLATION

Sizes ½" to 3" Figure 930 are standard with NPT inlet and outlet connections. The 4" is standard (optional 1" to 3") with ANSI Class 125 or 250 flanged inlet and NPT outlet. The inlet and outlet connections are the same size. Consult the drawings of record to verify the configuration supplied and installed.

The valve must be installed in an upright vertical orientation, normally at a high point in the system.

If installed outdoors, below ground in a vault or in an unheated area, adequate freeze protection must be provided. Some discharge of water may occur just prior to valve closure. If installed indoors or in a vault, the valve outlet should be directed to an adequate drain.

An isolating valve should be installed between the valve and the pipeline or system to facilitate maintenance.

Carefully screw threaded end valves onto pipe nipple using compatible thread sealant. Tighten valve using wrench flats. DO NOT OVERTIGHTEN.

Flat-faced flanged valves should be mated with flat-faced flanges and full-face gaskets. If ring gaskets are used the bolt material shall be ASTM A307 Grade B (or equivalent). Higher strength bolting should only be used with full-face gaskets.

Lower heavy valves using slings or chains around the valve body and/or the lifting eye. Lubricate the bolts or studs and insert around flange. Lightly tighten bolts until gaps are



eliminated. Torque bolts in an alternating pattern in graduated steps. If leakage occurs wait 24 hours and re-torque the bolts but do not compress the gasket more than 50% or exceed bolt maximum torque rating.

### VALVE CONSTRUCTION

The standard Figure 930 Air & Vacuum Valve has a cast iron body and cover, a 316 stainless steel float ball and Buna-N rubber seat. Refer to the List of Materials submitted for the order if non-standard materials were provided.

Refer to Figure 1 or 2 on Page 3 for details of construction and parts location.

All Figure 930 Air & Vacuum Valves have a 10 PSI minimum working pressure. Maximum working pressure for Figure 930-DT Class 125 flanged inlet valves is 150 PSI. Figure 930-T NPT inlet and Figure 930-UT Class 250 flanged inlet valves have a 300 PSI maximum working pressure.

The body (1) has an inlet connection at the bottom where the valve attaches to the system and an outlet connection at the top through which air leaves the valve (during filling) and enters the valve (during draining). The outlet may be fitted with a "cowl" to deflect air during venting and minimize entry of foreign matter during air admission.

<p style="text-align: center;"><b>WARNING</b></p> <p style="text-align: center;">Removing the valve from the line or disassembling the valve while there is pressure in the valve body may result in injury or damage to the valve</p>
--

### PREVENTIVE MAINTENANCE

Figure 930 Air & Vacuum Valves require no scheduled lubrication, adjustment or preventive maintenance.

The float ball with attached float guide are the only moving parts and require no lubrication.

A periodic visual inspection should be performed to ensure the outlet piping is not obstructed and to verify there is no fluid leakage.

### TESTING

Valve operation can be easily tested. Close the inlet isolation valve and remove or loosen the pipe plug nearest the inlet to drain the water

from the valve. The float should drop as the water leaves the valve. NOTE: A ball or gate valve can be installed in place of the pipe plug to facilitate testing.

Replace or tighten the pipe plug and slowly open the inlet isolating valve. The valve should float closed and seat tightly.

### TROUBLESHOOTING

- Valve Does Not Close / Fluid Leakage  
Verify debris has not collected on the seat preventing tight closure

Verify there is at least 10 PSI pressure at the valve inlet

Verify rubber seat and/or float ball seating surfaces are not deformed or damaged

Verify float guide is undamaged and attached to float

Verify float has buoyancy

Verify float ball rises freely without binding or sticking

- Valve Does Not Open  
Verify there is no debris in the valve that is preventing the float from freely falling when fluid is drained from valve

### DISASSEMBLY

Although small a size Figure 930 Air & Vacuum Valve may be more easily serviced by removing it from the line, all valves can be serviced while the body remains connected to the pipeline. A skilled technician with proper tools should perform all work. No special tools are required.

First ensure there is no pressure within the valve. Remove the cover screws (7) and lift off cover (2), it may be necessary to pry the cover off.

Remove the rubber seat (3) and lift out the float ball (5) with float guide (8) attached. Remove the rubber cushion (9) and flange bearing (10).

Inspect all parts for wear and damage. Minor scratches in the float are normal. Some floats may contain sand for added weight but if water is detected replace the float. Clean any scale build up from the float ball. Replace damaged parts.

## REASSEMBLY

Reassembly is performed in reverse order from disassembly. Clean all parts especially the threaded, seating and sealing surfaces before reassembling valve. Worn or damaged parts should be replaced.

Carefully introduce pressure and check for leaks

## REPAIR KITS

Soft Goods Repair Kits are available and include Items 3 and 9. Order by kit number or part number:

½" to 1" Kit A930 Part Number 2-80-11000-011

2" Kit A930-2 Part Number 2-80-11000-014

3" Kit A930-3 Part Number 2-80-11000-015

4" Kit A930-4 Part Number 2-80-11000-016

Other parts are ordered individually.

## REPLACEMENT PARTS

Genuine replacement parts are available from your local VAG/GA Industries representative or from the factory:

VAG USA, LLC  
 234 Clay Avenue  
 Mars, PA 16046 USA  
 Telephone: 724-776-1020  
 Fax: 724-776-1254  
 E-mail: [quotes-ga@vag-group.com](mailto:quotes-ga@vag-group.com)

Please have the nameplate data available when ordering parts.

## WARRANTY

The Warranty for GA Industries valves is included in our Terms and Conditions which can be found here: <https://gaindustries.com/terms>

### PARTS LIST ½" to 4" Figure 930

Item	Name	Standard Material
1.	Body	Cast Iron
2.	Cover	Cast Iron
3.	Seat	Buna-N Rubber
4.	Cover Bolts	Steel, Zinc Plated
5.	Float Ball	316 Stainless Steel
6.	Pipe Plug	Malleable Iron
7.	Cover Nuts	Steel, Zinc Plated
8.	Float Guide	½" – 3" UHMW Polyethylene 4" – Stainless Steel
9.	Cushion	Buna-N Rubber
10.	Bearing	Acetal Polymer
11.	Pipe Nipple	Brass
12.	Flange	Cast Iron

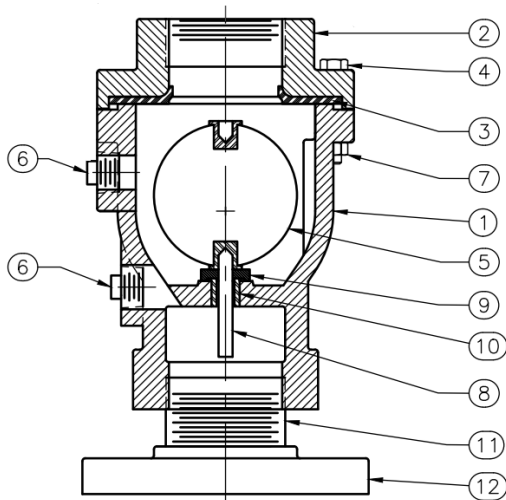

Figure 1 Standard NPT Inlet  
 (Parts 11 & 12 Only on Optional Flanged Inlet)

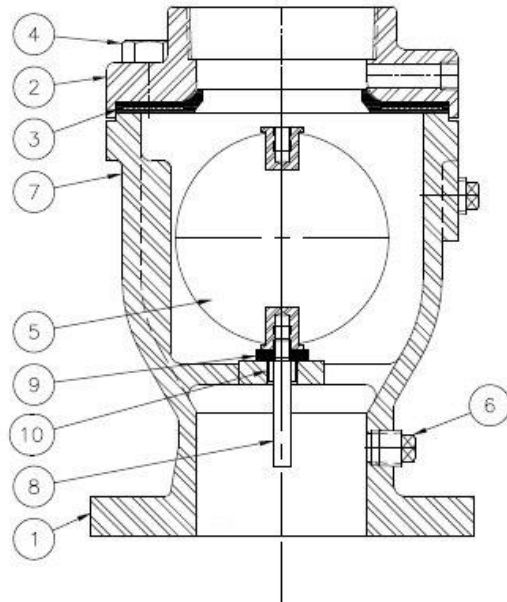

Figure 2  
 Flanged Inlet

### VAG USA, LLC

234 Clay Avenue • Mars, PA 16046 USA  
 Phone: 724-776-1020 • Fax: 724-776-1020  
[info-ga@vag-group.com](mailto:info-ga@vag-group.com) •  
[www.gaindustries.com](http://www.gaindustries.com)

# Section 3

# INSTALLATION, OPERATION AND MAINTENANCE MANUAL

## Figure 905

**1/2", 3/4" & 1" Air Release Valves**

**Drawing EAV-7010**



234 Clay Avenue  
Mars, PA 16046 USA  
Telephone (724) 776-1020  
Fax (724) 776-1254  
E-mail: [info-ga@vag-group.com](mailto:info-ga@vag-group.com)

905-IOM 022620 Rev B



WARNING: Cancer and Reproductive Harm – [www.Prop65Warnings.ca.gov](http://www.Prop65Warnings.ca.gov)

# INSTALLATION, OPERATION and MAINTENANCE

## Figure 905 Air Release Valves

### INTRODUCTION

This manual will provide the information to properly install, operate and maintain the valve to ensure a long service life. The Figure 905 Air Release Valve is ruggedly constructed to provide years of trouble-free operation with minimal maintenance.

These Air Release Valves are not intended for use with fluids containing suspended solids such as wastewater and sewage. The GA Industries Figure 925, 927 or 929 Air Release Valves are recommended for such applications.

#### CAUTION

The valve is NOT recommended for use with toxic fluids, fuels or fluids containing hazardous gases

#### CAUTION

The valve will not function if used at a pressure higher than the maximum working pressure indicated on the nameplate.

The Shop Order (SO) Number, Figure Number, size and pressure rating are stamped on a nameplate attached to the valve. Please refer to the SO number when ordering parts.

### DESCRIPTION OF OPERATION

The Figure 905 Air Release Valve is designed to automatically vent air that has accumulated within the valve. These valves are usually installed at high points in the system where air tends to collect. The valve is "normally open" as shipped and will vent air through its orifice at the top of the valve. The float rises when water enters the valve and closes the orifice. Air from the system accumulates in the valve forcing the water level down until the float drops and opens the venting orifice. As air is released the water level rises lifting the float and re-closing the valve.

This sequence occurs as often as necessary to release air that has collected in the valve.

### RECEIVING AND STORAGE

Inspect the valve upon receipt for damage during shipment. Carefully unload all valves to the ground without dropping.

The valves should remain in a clean, dry and weather protected area until installed. For long term storage (greater than 6 months) the rubber surfaces of the seat should be coated with a non-toxic lubricant such as "SuperLube" made by Synco Chemical. Do not expose the rubber parts to sunlight or ozone.

### INSTALLATION

The Figure 905 is standard with NPT screwed connections. Consult the drawings of record to verify the configuration supplied and installed.

The valve must be installed in an upright vertical orientation, normally at a high point in the system.

If installed outdoors, below ground in a vault or in an unheated area, adequate freeze protection must be provided. Some discharge of water may occur during operation so the valve outlet should be piped to an adequate drain.

An isolating valve should be installed between the valve and the pipeline or system to facilitate maintenance.

Carefully screw threaded end valves onto pipe nipple using compatible thread sealant. Tighten valve using wrench flats. DO NOT OVERTIGHTEN.

### VALVE CONSTRUCTION

The standard Figure 905 Air Release Valve has a cast iron body, stainless steel float and linkage mechanism and a rubber seat and is suitable for use at working pressures from 10 to 150 PSI (69 to 1,034 kPa). If there is an "H" suffixed to the figure number (e.g., 905H) the valve is suitable for use at up to 200 PSI (1,379 kPa) working pressure. Refer to the List of Materials

submitted for the order if non-standard materials were provided.

Refer to Page 4 for details of construction and parts location.

The body (1) has an inlet connection at the bottom where the valve attaches to the system and a smaller outlet connection at the top through which air leaves the valve.

#### **WARNING**

Removing the valve from the line or disassembling the valve while there is pressure in the valve body may result in injury or damage to the valve

#### **PREVENTIVE MAINTENANCE**

Figure 905 Air Release Valves require no scheduled lubrication, adjustment or preventive maintenance.

A periodic visual inspection should be performed to ensure the outlet piping is not obstructed and to verify there is no fluid leakage.

#### **TESTING**

Valve operation can be easily tested. Close the inlet isolation valve and remove or loosen the pipe plug nearest the inlet to drain the water from the valve. The float should drop as the water leaves the valve. NOTE: A ball or gate valve can be installed in place of the pipe plug to facilitate testing.

Replace or tighten the pipe plug and slowly open the inlet isolating valve. The valve should float closed and seat tightly.

#### **TROUBLESHOOTING**

- Valve Does Not Close / Fluid Leakage  
Verify debris has not collected on the seat preventing tight closure

Verify rubber orifice button and/or orifice seating surfaces are not damaged

Verify float has buoyancy

Verify linkage mechanism operates freely without binding or sticking

Verify pressure at valve inlet is at least 10 PSI

- Valve Does Not Open  
Verify debris in the valve is not preventing the float from freely falling when fluid is drained from valve

Verify linkage mechanism operates freely without binding or sticking

Verify pressure at valve inlet does not exceed maximum working pressure

#### **DISASSEMBLY**

Although the Figure 905 air release valve may be more easily serviced by removing it from the line, all valves can be serviced while the body remains connected to the pipeline. A skilled technician with proper tools should perform all work. No special tools are required.

First ensure there is no pressure within the valve. Remove the cover screws (13) and lift off cover (2) with float and linkage attached. It may be necessary to pry the cover off. Be careful not to damage or lose the cover gasket (3) unless it will be replaced.

Remove the spring pin (14) to free the float arm (5) with float ball (9) attached. Remove the rubber orifice button (7) by pulling it out of the float arm (5). No further disassembly is needed to replace the rubber orifice button (10)

Use a 1/2" hex socket to remove the orifice (4) and lift off the leverage bracket (6).

Remove the float screw (10) being careful not to lose the lock washer (11).

Inspect all parts for wear and damage. Minor scratches and dents in the float are normal. Some floats may contain sand for added weight but if water is detected replace the float. Carefully clean the orifice of scale. Replace damaged parts.

#### **REASSEMBLY**

Reassembly is performed in reverse order from disassembly. Clean all parts especially the threaded, seating and sealing surfaces before reassembling valve. Worn parts should be replaced.

Clean with Loctite 649 (or equal) primer and apply Loctite® 271 (or equal) sealant to the threads of the orifice (4) before installation into cover. Torque to maximum 22 ft-lbs.

Lubricate orifice button (7) and pull the small end through the hole in the float arm (5) until it locks in place.

Apply Loctite 242 (or equal) to the threads of the float screw (10) before installation. Align float arm with the bracket and install spring pin.

Place cover gasket (3) and cover (2) with the float assembled on the body and install cover screws. Tighten cover screws in an alternating pattern.

Carefully introduce pressure and check for leaks

### REPLACEMENT PARTS

Genuine replacement parts are available from your local VAG/GA Industries representative or from the factory:

VAG USA, LLC  
 234 Clay Avenue  
 Mars, PA 16046 USA  
 Telephone: 724-776-1020  
 Fax: 724-776-1254  
 E-mail: [quotes-ga@vag-group.com](mailto:quotes-ga@vag-group.com)

Please have the nameplate data available when ordering parts.

### REPAIR KITS

Soft Goods Kit A905 (Part Number 2-80-11000-002) includes items 3 and 7.

Linkage Kit AL905 (Part Number 2-80-11000-078) includes items 5, 6, 8 and 14.

### WARRANTY

The Warranty for GA Industries valves is included in our Terms and Conditions which can be found here: <https://gaindustries.com/terms>

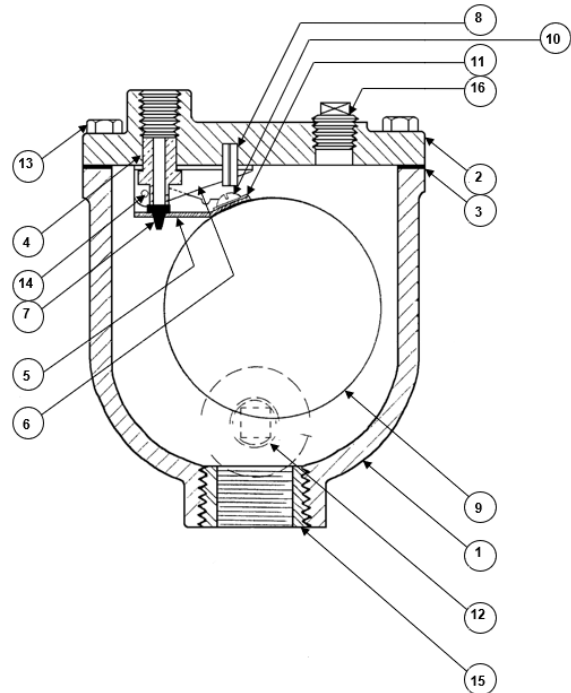

**Figure 905 Air Release Valve**

Item	Description	Standard Material
1	Body	Cast Iron
2	Cover	Cast Iron
3	Cover Gasket	Buna N Rubber
4	Orifice	316 SS
5	Float Arm	316 SS
6	Leverage Bracket	316 SS
7	Orifice Button	Buna N Rubber
8	Spirol Pin	302 SS
9	Float Ball	316 SS
10	Float Screw	304 SS
11	Lock Washer	302 SS
12	Pipe Plug	Steel
13	Cover Screw	Zinc Plated Steel
14	Spirol Pin	302 SS
15	Reducing Bushing*	Steel

\* Used only for 1/2" or 3/4" connection size

# Section 4



# INSTALLATION, OPERATION AND MAINTENANCE MANUAL

## Figure F284-D Anti-Slam Surge Check Valves



234 Clay Avenue  
Mars, PA 16046 USA  
Telephone (724) 776-1020  
Fax (724) 776-1254  
E-mail: [info-ga@vag-group.com](mailto:info-ga@vag-group.com)

IOM F284D 070822



WARNING: Cancer and Reproductive Harm – [www.Prop65Warnings.ca.gov](http://www.Prop65Warnings.ca.gov)

# INSTALLATION, OPERATION and MAINTENANCE

## Anti-Slam Surge Check Valves

### INTRODUCTION

This manual will provide the information to properly install, operate and maintain the valve to ensure a long service life. GA Industries Surge Check Valves are ruggedly constructed to provide years of trouble-free operation with minimal maintenance.

#### CAUTION

The valve is NOT recommended for use with compressed air or other gases.

#### CAUTION

Surge Check Valves are not intended for use with hazardous, flammable, or toxic fluids.

The Shop Order (SO) Number, Figure Number, size and pressure rating are stamped on a nameplate attached to the valve. Please refer to the SO number when ordering parts.

### DESCRIPTION OF OPERATION

GA Industries Anti-Slam Surge Check Valves are designed to minimize the surge pressure and valve damage that can result when an air & vacuum valve is suddenly closed by the high velocity incoming water. The surge check valve automatically closes to restrict the discharge area upon excessive air discharge velocity or a sudden transition from air to water. The restricted area slows the incoming water velocity, the air valve is not slammed shut and surges are minimized.

Once the air valve is closed, the surge check reopens to allow unrestricted air inflow.

### RECEIVING AND STORAGE

Inspect the valve upon receipt for damage during shipment. Carefully unload all valves to the ground without dropping.

The valves should remain in a clean, dry, and weather protected area until installed. For long term storage (greater than 6 months) the rubber surfaces of the seat should be coated with a non-toxic lubricant such as "SuperLube" made

by Synco Chemical. Do not expose the rubber parts to sunlight or ozone.

### VALVE CONSTRUCTION

GA Industries Figure F284-D Anti-slam Surge Check Valves have a globe style valve body with integral flanges that are faced and drilled per ANSI Class 125/150.

The valve has a fusion bond epoxy coated ductile iron body, lead free bronze internal metal components and a rubber seat. Refer to Page 4 for details of construction and parts location.

### INSTALLATION

GA Industries Figure 284-D Anti-Slam Surge Check Valves are usually supplied as a component of a factory assembly consisting of an air & vacuum valve or combination air valve and a surge check valve.

The Figure 284-D can also be supplied as a separate valve for field installation between the air & vacuum valve or combination air valve and its inlet isolating valve. In this case ensure the valve is installed so that the end of the valve that has the bronze seat with "spokes" is connected to the air valve.

#### CAUTION

**Do not lift the valve by the bronze seat ring spokes**

The valve should be installed between standard ANSI Class 125 or 150 flat faced flanges. Full face flange gaskets are recommended.

Remove all packing materials from the valve, including the tabs that retain the seat during shipping.

If ring gaskets are used the bolt material shall be ASTM A307 Grade B (or equivalent). Higher strength bolting should only be used with full-face gaskets.

Lower heavy valves using slings or chains around the valve body. Lubricate the bolts or studs and insert around flange. Lightly tighten bolts until gaps are eliminated. Torque bolts in an alternating pattern in graduated steps. If leakage occurs wait 24 hours and re-torque the bolts but do not compress the gasket more than 50% or exceed bolt maximum torque rating.

If installed outdoors, below ground in a vault or in an unheated area, adequate freeze protection must be provided.

Sizes 10-inch and smaller Figure F284-D Anti-Slam Surge Check Valves have enough clearance to allow it to be bolted to most butterfly valves. Refer to Table 1 on page 4 for clearance dimensions. However, the plug shaft in 12-inch size valves extends past the outlet flange and will interfere with an adjacent butterfly valve's operation.

#### **PREVENTIVE MAINTENANCE**

GA Industries Figure 284-D Anti-Slam Surge Check Valves require no scheduled lubrication, adjustment, or preventive maintenance but a periodic visual inspection should be performed.

#### **TROUBLESHOOTING**

If the associated air valve slams shut, close one or more of the restriction ports in the Anti-Slam Surge Check Valve disc by installing pipe plug(s).

<p style="text-align: center;"><b>WARNING</b></p> <p style="text-align: center;">Removing the valve from the line or disassembling the valve while there is pressure in the valve body may result in injury or damage to the valve</p>
--

#### **DISASSEMBLY**

The valve should be removed from the line before disassembly. A skilled technician with proper tools should perform all work. No special tools are required.

Set the valve, with the flow arrow pointing down, on wooden blocks or 2 x 4's under the flange outboard of the bronze seat so that it can drop out of the body. Ensure the surface beneath the valve will not damage the internal components when they drop out of the valve.

Place a metal rod on top of the stem inside the bushing. Hit the top of the rod with a hammer or

mallet and the internal components should drop out of the valve body.

Inspect the seating surfaces. Superficial marks, or discoloration on the mating surface of the poppet are normal. The rubber seat is retained in a "dove-tail" groove in the seat and can be pulled out if damaged

Inspect the plug for damage, especially the guiding surfaces to ensure they have not worn unevenly. If they are not round, it can lead to misalignment and sticking so they should be replaced.

#### **REASSEMBLY**

Clean all parts especially the seating and sealing surfaces before reassembling valve. Worn parts should be replaced.

Set valve body on a flat surface with the flow arrow pointing down. Install bushing (2) into body (1). Set spring (3) over bushing (2). Install poppet stem in bushing. Lubricate and install new O-ring in dove-tail groove in seat being careful not to damage or cut the O-ring during installation.

Lubricate the O-Ring (6) and install in the groove on the OD of the seat. It is very important to lubricate this O-ring to prevent damage during installation which will cause a leak and not allow the seat to enter the body.

Place the seat into the valve making sure the seat stem enters the poppet and the poppet enters the bushing.

Using two hands, push down on the seat to pop it into the body. Larger valves may require a 2 x 4 to be placed across the seat and hit with a hammer.

Install valve in line with new gaskets, tighten flange bolts, carefully introduce pressure and check for leaks

**REPLACEMENT PARTS**

Genuine replacement parts are available from your local VAG/GA Industries representative or from the factory:

VAG USA, LLC  
 234 Clay Avenue  
 Mars, PA 16046 USA  
 Telephone: 724-776-1020  
 Fax: 724-776-1254  
 E-mail: [quotes-ga@vag-group.com](mailto:quotes-ga@vag-group.com)

Please have the nameplate data available when ordering parts.

**WARRANTY**

The Warranty for GA Industries valves is included in our Terms and Conditions which can be found here: <https://gaindustries.com/terms>

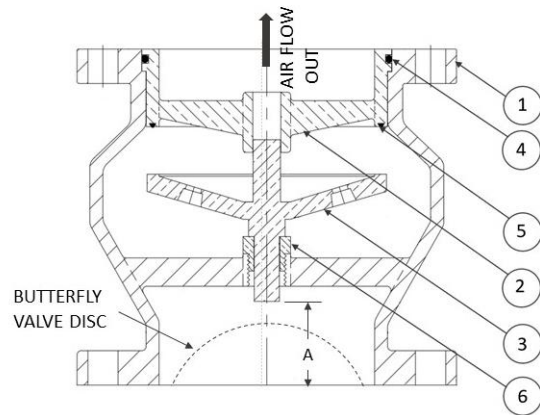

**Anti-Slam Surge Check Valve**

Item	Description	Standard Material
1	Body	Ductile Iron
2	Seat	Lead Free Bronze
3	Poppet	Lead Free Bronze
4	Seat O-Ring	EPDM Rubber
5	Seal	EPDM Rubber
6	Bushing	Bronze

**Table 1 Butterfly Valve Disc Clearance**

Size	A
2½"	1¾"
3"	1¾"
4"	1¾"
6"	2½"
8"	3¼"
10"	4¼"
12"	Not applicable