

INSTALLATION, OPERATION AND MAINTENANCE MANUAL

Figures 991-D and 991-U Drawing EAV-7080, 3” to 20” Wastewater Vacuum Breaking Valves

TABLE OF CONTENTS

Introduction	1
Description of Operation	1
Receiving & Storage	1
Installation	1
Valve Construction	1
Start-Up	2
Preventive Maintenance	2
Trouble Shooting	2
Disassembly	2
Assembly	2
Replacement Parts List.....	3
Warranty	3
Assembly Drawing/Parts Location.....	4



234 Clay Avenue • Mars, PA 16046 USA
Telephone (724) 776-1020 • Fax (724) 776-1254
E-mail: info-ga@vag-group.com

Manual Number 991-IOM-022321 Rev A



WARNING: Cancer and Reproductive Harm – www.Prop65Warnings.ca.gov

INSTALLATION, OPERATION and MAINTENANCE

Figures 991-D and 991-U Wastewater Vacuum Breaking Valves

INTRODUCTION

This manual will provide the information to properly install, operate and maintain the valve to ensure a long service life. The Figure 991 Vacuum Breaking Valve is ruggedly constructed to provide years of trouble-free operation with minimal maintenance.

CAUTION

The valve is NOT recommended for use with toxic or highly corrosive fluids, fuels or fluids containing hazardous gases

The Shop Order (SO) Number, Figure Number, size and pressure rating are stamped on a nameplate attached to the valve. Please refer to the SO number when ordering parts.

DESCRIPTION OF OPERATION

The Figure 991 Vacuum Breaking Valve is counter-weighted rubber-seated valve specifically designed for use with fluids containing stringy solids and debris. It is normally closed and opens to open to admit air when the pressure inside the valve falls a pre-set amount below atmospheric pressure. It opens as far as needed to admit air at the rate necessary to limit further vacuum formation. The valve will close when the internal pressure recovers to atmospheric and remain closed when the pressure inside the valve is above atmospheric.

RECEIVING AND STORAGE

Inspect the valve upon receipt for damage during shipment. Carefully unload all valves to the ground without dropping.

The valves should remain in a clean, dry, and weather protected area until installed. For long term storage (greater than 6 months) the rubber surfaces of the seat should be coated with a non-toxic lubricant such as "SuperLube" made by Synco Chemical. Do not expose the rubber parts to sunlight or ozone.

INSTALLATION

Figure Numbers suffixed with "D" (e.g., 991-D) indicate the valve has an ANSI Class 125 flanged pipeline connection, Figure Numbers suffixed with "U" (e.g., 991-U) indicate the valve has an ANSI Class 250 flanged connection.

The valve must be installed in a vertical orientation and plumb. The counterweight arm must be horizontal when the valve is closed.

Prior to installation ensure all debris, packing material or other foreign material has been removed from both ports.

If installed outdoors, below ground in a vault or in an unheated area, adequate freeze protection must be provided.

An isolating valve should be installed between the valve and the pipeline or system to facilitate maintenance.

The valve is not designed to support adjacent equipment; piping loads should not be imposed on the valve and large valves should be properly supported. Ensure mating flanges are square and parallel to the valve flanges before tightening flange bolts.

Flat-faced flanged valves should be mated with flat-faced flanges and full-face gaskets. If ring gaskets are used the bolt material shall be ASTM A307 Grade B (or equivalent). Higher strength bolting should only be used with full-face gaskets.

Lower heavy valves using slings or chains around the valve body and/or the lifting eye. Do not lift by the "cowl" or counterweight arm. Lubricate the bolts or studs and insert around flange. Lightly tighten bolts until gaps are eliminated. Torque bolts in an alternating pattern in graduated steps. If leakage occurs wait 24 hours and re-torque the bolts but do not compress the gasket more than 50% or exceed bolt maximum torque rating.

VALVE CONSTRUCTION

The standard Figure 991 has a cast iron body, bronze or stainless steel body seat, stainless steel hinge shaft and cast iron disc with a rubber disc seat. Refer to the List of Materials submitted for the order if non-standard materials were provided.

Refer to Page 4 for details of construction and parts location.

START-UP

The valve generally does not require any calibration or adjustment prior to start-up. The counterweight(s) should be initially placed at the far end of the arm and secured by tightening the set screw (31A).

The valve should smoothly swing open as air flow through the valve increases. The amount of opening depends on the flow velocity through the valve and can be observed by watching the external counterweight arm. The valve is "full ported" at about 25 degrees of swing but can swing open as much as 60 degrees.

PREVENTIVE MAINTENANCE

No routine lubrication or adjustments are needed. A periodic visual inspection should be conducted to ensure the air inlet screen is not obstructed and to verify there is no fluid leakage.

TROUBLESHOOTING

- Shaft packing leakage
Tighten packing gland nuts equally just enough to stop leakage, no more than ½ turn at a time. DO NOT OVER-TIGHTEN!
Replace packing if necessary.
- Leakage past seat when closed
Inspect valve for debris, clean
Inspect seating surfaces for damage, replace as necessary
- Leakage past cover or flange gaskets
Tighten cover or flange bolts

WARNING

Removing the valve from the line or disassembling the valve while there is pressure in the valve body may result in injury or damage to the valve

WARNING

Follow all applicable safety regulations and codes and read and understand all instructions before undertaking disassembly.

DISASSEMBLY

All Figure 991 valves can be serviced while the body remains connected to the pipeline. A skilled technician should perform all work. No special tools are required.

First ensure there is no pressure within the valve and operating equipment is tagged and locked out. Refer to pages 3 and 4 for parts identification and location.

It is not necessary to disassemble the entire valve to replace the shaft packing, follow steps 1 to 3 and 5a.

1. Ensure there is no pressure within the valve and operating equipment is locked out.
2. Mark the position of the counterweight(s) on the arm. Loosen the counterweight set screw (31A) and slide the weight(s) off the arm. Loosen the counterweight arm set

3. Loosen and remove the gland stud nuts (16), slide off the gland (15) and remove the shaft packing (17).
4. Remove the end plate bolts (35), the end plate (34) being careful not to lose or damage the end plate seal (36) unless it is to be replaced
5. Remove the cover bolts (10) and lift off the cover (9). If necessary, carefully pry the cover off using a cold chisel between the body and cover. Be careful not to damage or lose the cover gasket (8) unless it is to be replaced.
6. Remove the shaft lock pin (18) by threading a screw into the tapped hole.
7. With the disc and disc arm properly supported, loosen the disc arm set screw (12) and pull the shaft (11) out of the valve. It may be necessary to drive out the shaft from the opposite end.
NOTE: The outer bushing (14) and disc arm key (19) should come out with the shaft. Be careful not to lose the disc arm key. After the shaft is out, remove the inner bushing (13) from the opposite side.
8. Carefully lift the disc arm assembly out of the body. Remove the disc nut pin (6B), disc nut (6) and disc nut washer (6A).
9. Remove the seat screws (5C), the seat follower (5B) and the renewable seat (5A) or metal seat washer (5D).
10. In the unlikely event it's necessary to remove the body seat (2), the spring pins holding it into the body must be compressed until they no longer "bite" into the body. This is best accomplished by compressing the seat pins (2B) using "vice-grips" and pulling the pins in a radial direction towards the valve centerline.

Inspect all parts for wear and damage. Replace damaged parts.

ASSEMBLY

The valve is reassembled by reversing the disassembly sequence with consideration of the following:

- 1a. Clean and polish all machined bearing and sealing surfaces. Apply a light coat of lubricant to assist in the assembly.
- 2a. Ensure the disc arm key slides inside the disc arm before installing the shaft lock pin (18). Ensure the shaft lock pin has dropped into the groove provided for it on the shaft.
- 3a. Install the inner and outer bushings then install the shaft packing. Install the end plate (34) with seal (36). Install and tighten the end plate bolts (35) while ensuring the

- end plate seal (36) remains in the groove provided for it in the end plate.
- 4a. Lift the disc assembly several times to ensure free closure with no metal-to-metal contact.
 - 5a. Wrap the packing around the shaft and cut on a 45-degree angle, staggering the cuts with each ring.
 - 6a. Tighten gland bolts evenly until packing is slightly compressed. After pressure has been introduced into the valve, re-tighten evenly until leakage stops.
 - 7a. Ensure cover gasket sealing surfaces are clean and apply a thin coat of Permatex™ #2 to both surfaces. Tighten cover nuts in an alternating pattern. Re-tighten as needed after pressure has been introduced.
 - 8a. Re-install the counterweight arm (30) with key (30B) and tighten counterweight set screws (30A).
 - 9a. Slide counterweight(s) onto shaft and lock in place using set screws (31A). Lift counterweight arm and allow it to fall to ensure free movement.

REPLACEMENT PARTS

Genuine replacement parts are available from your local VAG/GA Industries representative or from the factory:

VAG USA, LLC
 234 Clay Avenue
 Mars, PA 16046 USA
 Telephone: 724-776-1020
 Fax: 724-776-1254
 E-mail: quotes-ga@vag-usa.com

Please have the nameplate data available when ordering parts. Identify needed part(s) by Shop Order (SO) Number, Figure Number, valve size and individual part number.

REPAIR KITS

Soft Goods Kit includes Items 2A 5A, 8, 17 & 36

Size	Kit Number	Part Number
2" to 3"	SW3	2-80-24000-218
4"	SW4	2-80-24000-222
6"	SW6	2-80-24000-225
8"	SW8	2-80-24000-228
10"	SW10	2-80-24000-200
12"	SW12	2-80-24000-203
14"	SW14	2-80-24000-206
16"	SW16	2-80-24000-209
18" & 20"	SW1820	2-80-24000-212
24"	SW24	2-80-24000-215

Soft Goods AND Disc/Disc Arm Assembly Kit includes above parts plus 3, 4, 5B, 5C, 6, 6A, 6B & 12.

Size	Kit Number	Part Number
2" to 3"	SW3D	2-80-24000-221
4"	SW4D	2-80-24000-224
6"	SW6D	2-80-24000-227
8"	SW8D	2-80-24000-230
10"	SW10D	2-80-24000-202
12"	SW12D	2-80-24000-205
14"	SW14D	2-80-24000-208
16"	SW16D	2-80-24000-211
18" & 20"	SW1820D	2-80-24000-213

All other parts ordered individually. Consult factory for larger sizes.

WARRANTY:

The Warranty for GA Industries valves is included in our Terms and Conditions which can be found here: <https://gaindustries.com/terms>

Part No.	Part Name	Std. Material
1	Body	Cast Iron
2	Body Seat	Bronze or SS
2.1	Seat O-Ring	Buna-N
2.2	Seat Pins	Stainless Steel
3	Disc with Center Pin	Cast Iron/Steel
4	Disc Arm	Ductile Iron
5	Renewable Seat	Buna-N
5.1	Seat Follower	Bronze or SS
5.2	Seat Screws	Stainless Steel
6	Disc Nut	Steel
6.1	Disc Nut Washer	Steel
6.2	Disc Nut Cotter Pin	Stainless Steel
8	Cover Gasket	Fiber
9	Cover	Steel
10	Cover Bolt (and Nut)	Steel
11	Shaft	Stainless Steel
12	Disc Arm Set Screw	Stainless Steel
13	Inner Bushing	Bronze
14	Outer Bushing	Bronze

Part No.	Part Name	Std. Material
15	Gland	Cast Iron
16	Gland Stud & Nut	Steel
17	Packing	Teflon
18	Shaft Lock Pin	Brass
19	Disc Arm Key	Stainless Steel
30	Counterweight Arm	Ductile Iron/Steel
30.1	C'weight Arm Set Screw	Stainless Steel
30.2	Counterweight Arm Key	Stainless Steel
31	Counterweight(s)	Cast Iron
31.1	Counterweight Set Screw	Stainless Steel
32	Cowl	Steel
32.1	Cowl Bolts	Steel
32.2	Screen	Stainless Steel
32.3	Cowl Nuts	Steel
2.4	Cowl Washer	Steel
33	Cover Plug (18" & 20" only)	Steel
34	Shaft End Plate	Steel
35	Shaft End Plate Screws	Steel
36	Shaft End Plate Seal	Buna-N
37	Stud Sleeve	Steel

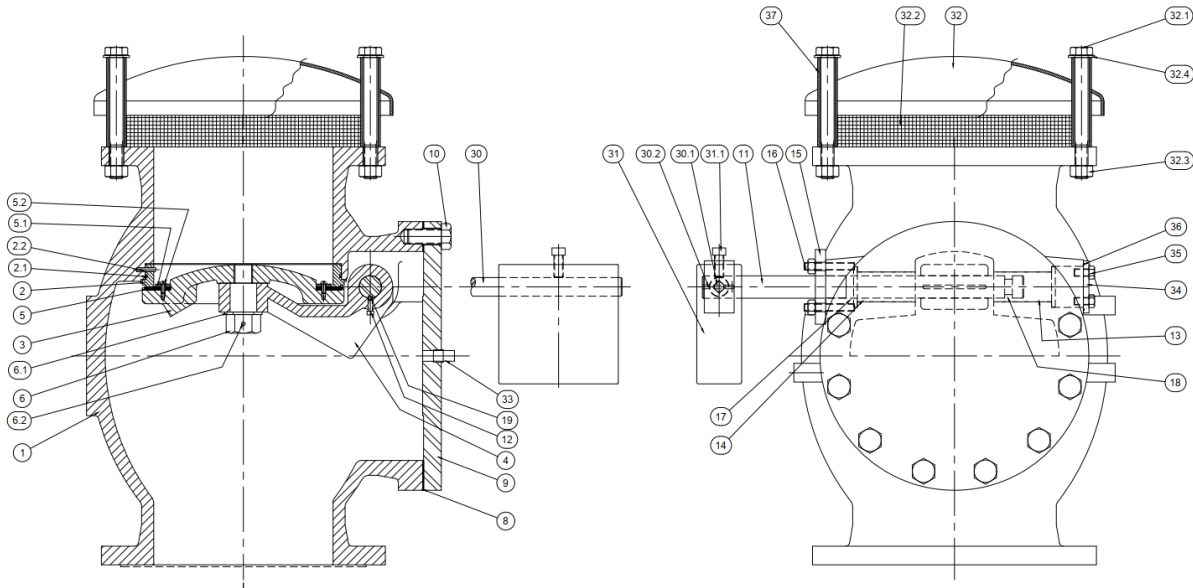

This page intentionally left blank.