

# Figure B517RF 100% Port Class 125 Flanged Eccentric Plug Valves For In-Plant/Exposed Service

## Description

The GA Industries Figure B517RF Eccentric Plug Valve is a rugged, field-proven valve that will provide many decades of trouble-free service. The valve has a port area equal to 100% of the inside area of the adjacent pipe providing the lowest possible head loss.

The Figure 517RF Eccentric Plug Valve has upper and lower thrust bearings, grit seals and all surfaces of the plug exposed to the flow are totally encapsulated in rubber.

The valve can be supplied with a manual worm gear and handwheel or a 2" square nut. Automatic actuation is also available.

## Standard Features

- Internal and external epoxy coated, high strength ductile iron body and cover
- 100% port area, up to 53 less head loss than standard rectangular port plug valves
- Bi-directional zero leakage
- Fully rubber encapsulated ductile iron plug
- Shaft packing adjustable and replaceable without removing the actuator
- 316SS external fasteners
- 316SS upper and lower shaft bearings
- Top and bottom lifting eyes and feet to facilitate handling and installation

## Standard Materials

- Body and Cover Ductile Iron, ASTM A536 Gr 65-45-12
- Body Seat Weld Overlaid 95% Pure Nickel
- Plug Ductile Iron, ASTM A536 Gr 65-45-12
- Plug Coating Buna-N Rubber, Molded and Vulcanized to the Plug
- Shaft Bearings 316 Stainless Steel
- Thrust Bearings Aluminum Bronze
- External Fasteners 316 Stainless Steel

## Corrosion Protection

- Standard: Internal and External PPG/Amerlok 400 2-Part Epoxy

## Ordering Data

- Figure Number B517RF
- Size
- Connections (Class 125 Flanged)
- Handwheel or 2" Operating Nut
- Options/Accessories

Data Sheet B517RF.01A



## Approvals & Certifications

- Fully complies with AWWA Standard C517

## Options and Accessories

- Option CW – With Chainwheel – Facilitates Operation of Overhead Worm Gear Operated Valves

Non-Shock Working Water Pressure at up to 180F (82C)	
Figure Number	<b>B517RF</b>
Connections	Class 125 Flanged
Manual Operation	Worm Gear with Handwheel      Worm Gear with 2" Nut
Size	24" to 54"
Direct Seating Max Pressure	150 PSI
Reverse Seating Max Pressure	24" – 150 PSI, 30" to 54" – 100 PSI
Hydro Test	225 PSI

Data Sheet B517RF.01A

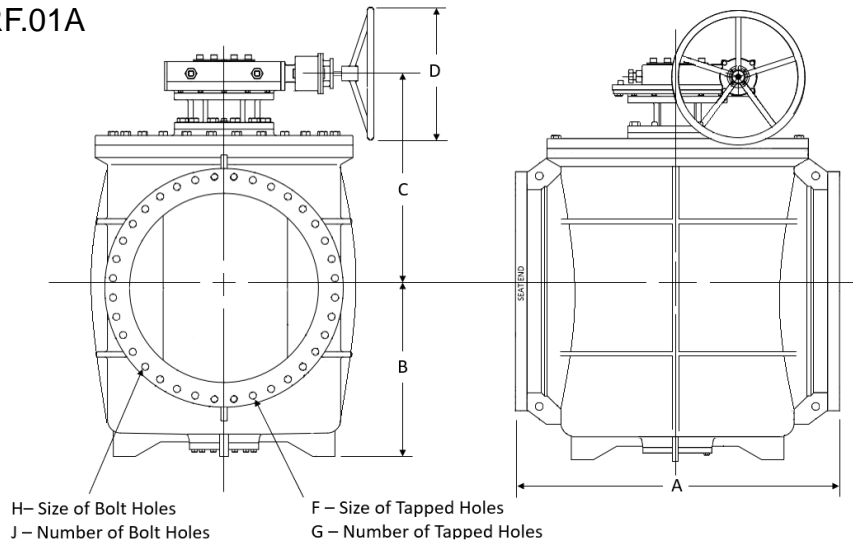

**Installation Dimensions**

SIZE	24"	30"	36"	42"	48"	54"
A	42	51	60	72	84	96
B	20.7	26.7	30.7	37.4	42.3	44.1
C	27.3	35.2	40.1	50.0	54.7	57.5
D	24	24	28	32	36	32
F	N/A	1½"-7UNC	1½"-6UNC	1½"-6UNC	1½"-6UNC	1½"-5UNC
G	N/A	8	8	4	4	4
H	1½"	1½"	1½"	1½"	1½"	2"
J	20	20	24	32	40	40
WGT	2,615	5,175	8,015	14,500	20,640	25,810

**Flow Coefficients**

SIZE	24"	30"	36"	42"	48"	54"
$C_v$	41,000	65,000	95,000	110,000	135,000	150,000
K	0.18	0.17	0.17	0.23	0.26	0.34

- Dimensions C and D represent standard worm gear actuator
- Worm gear actuator can be rotated in 90-degree increments about valve centerline
- Valve can be supplied with 2" operating nut instead of handwheel
- Consult factory for valves with automatic actuators
- Dimensions in inches and weight in pounds and are approximate. Request certified drawings if critical.

