

# Figure B517RF 100% Port Class 125 Flanged Eccentric Plug Valves For In-Plant/Exposed Service

## Description

The GA Industries Figure B517RF Eccentric Plug Valve is a rugged, field-proven valve that will provide many decades of trouble-free service. The valve has a port area equal to 100% of the inside area of the adjacent pipe providing the lowest possible head loss.

The Figure B517RF Eccentric Plug Valve epoxy coated ductile iron body has upper and lower thrust bearings, grit seals and all surfaces of the ductile iron plug exposed to the flow are totally encapsulated in rubber.

The valve can be supplied with a manual worm gear with visual position indicator and handwheel or an optional chainwheel or 2" square nut. Automatic actuation is also available.

## Standard Features

- Internal and external epoxy coated, high strength ductile iron body and cover
- 100% port area, up to 53% less head loss than standard port valves
- Bi-directional zero leakage
- Fully rubber encapsulated ductile iron plug
- Shaft packing adjustable and replaceable without removing the actuator
- 316SS external fasteners
- 316SS upper and lower shaft bearings
- Lifting eyes and feet to facilitate handling and installation

## Standard Materials

- Body and Cover Ductile Iron, ASTM A536 Gr 65-45-12
- Body Seat Weld Overlaid 95% Pure Nickel
- Plug Ductile Iron, ASTM A536 Gr 65-45-12
- Plug Coating Buna-N Rubber, Molded and Vulcanized to the Plug
- Shaft Bearings 316 Stainless Steel
- Thrust Bearings Aluminum Bronze
- External Fasteners 316 Stainless Steel

## Corrosion Protection

- Standard: Internal and External PPG/Amerlok 400 2-Part Epoxy

## Ordering Data

- Figure Number B517RF
- Size
- Connections (Class 125 Flanged)
- Options/Accessories

Data Sheet B517RF.01G



## Approvals & Certifications

- Fully complies with AWWA Standard C517

## Options and Accessories

- Option CW Chainwheel in lieu of Handwheel, Facilitates Operation of Overhead Worm Gear Operated Valves
- Option WS 2" Square Nut in lieu of Handwheel

Non-Shock Working Water Pressure at up to 180F (82C)	
Figure Number	<b>B517RF</b>
Connections	Class 125 Flanged
Manual Operation	Worm Gear with Handwheel   Worm Gear with 2" Nut
Size	24" to 60"
Direct Seating Max Pressure	150 PSI
Reverse Seating Max Pressure	24" to 36" – 150 PSI, 42" to 54" – 100 PSI, 60" – 50 PSI
Hydro Test	225 PSI

Data Sheet B517RF.01G

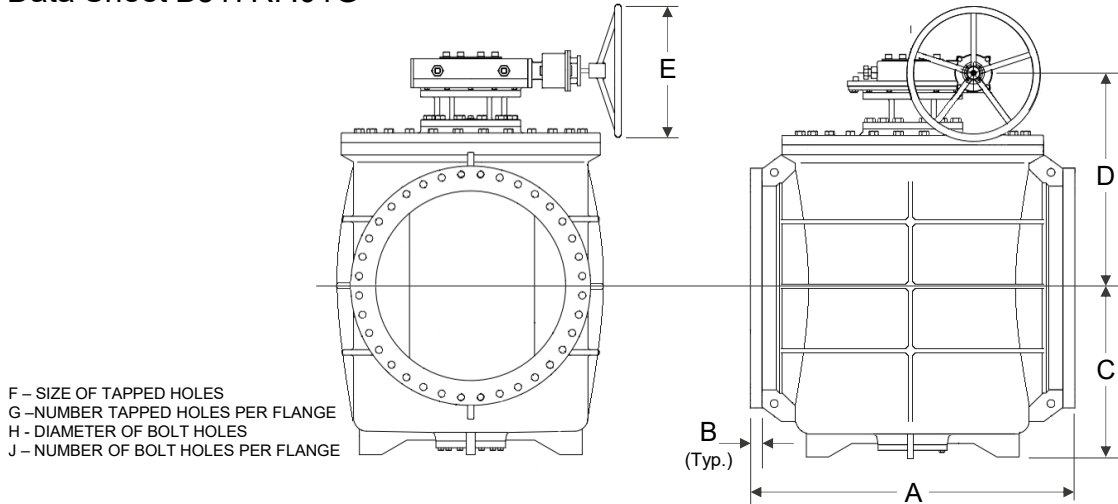

**Installation Dimensions**

SIZE	24"	30"	36"	42"	48"	54"	60"
A	42	51	60	72	84	96	96
B	1 $\frac{1}{8}$	2 $\frac{1}{8}$	2 $\frac{3}{8}$	2 $\frac{3}{8}$	3	3	3 $\frac{1}{8}$
C	20%	26%	30 $\frac{3}{4}$	37 $\frac{1}{2}$	44%	43 $\frac{3}{4}$	48
D	26 $\frac{1}{2}$	33 $\frac{3}{8}$	38%	48 $\frac{3}{8}$	57%	56 $\frac{1}{2}$	60 $\frac{1}{2}$
E	24	24	28	32	36	32	32
F	N/A	1 $\frac{1}{4}$ "- 7UNC	1 $\frac{1}{2}$ "- 6UNC	1 $\frac{1}{2}$ "- 6UNC	1 $\frac{1}{2}$ "- 6UNC	1 $\frac{3}{4}$ "- 5UNC	1 $\frac{3}{4}$ "- 5UNC
G	N/A	8	8	4	4	4	4
H	1 $\frac{1}{8}$	1 $\frac{1}{8}$	1 $\frac{1}{8}$	1 $\frac{1}{8}$	1 $\frac{1}{8}$	2	2
J	20	20	24	32	40	40	48
WGT	2,615	5,175	8,015	14,500	20,640	25,810	33,835

**Flow Coefficients (Direct Seating)**

SIZE	24"	30"	36"	42"	48"	54"	60"
C <sub>v</sub>	26,439	39,548	60,175	78,900	120,635	164,500	199,845
K	0.42	0.46	0.41	0.45	0.33	0.28	0.29

**Flow Coefficients (Reverse Seating)**

SIZE	24"	30"	36"	42"	48"	54"	60"
C <sub>v</sub>	27,000	40,110	62,485	79,150	126,600	170,100	205,600
K	0.41	0.45	0.38	0.44	0.30	0.26	0.27

- Dimensions D and E represent standard worm gear actuator
- Worm gear actuator can be rotated in 90-degree increments about valve centerline
- Valve can be supplied with 2" operating nut or chainwheel instead of handwheel
- Consult factory for valves with automatic actuators
- Dimensions in inches and weight in pounds and are approximate. Request certified drawings if critical.

