

Figure B517RF 100% Port Mechanical Joint (MJ) Eccentric Plug Valves For Buried Service

Description

The GA Industries Figure B517RF Eccentric Plug Valve is a rugged, field-proven valve that will provide many decades of trouble-free service. The valve has a port area equal to 100% of the inside area of the adjacent pipe providing the lowest possible head loss.

The Figure 517RF Eccentric Plug Valve has upper and lower thrust bearings, grit seals and all surfaces of the plug exposed to the flow are totally encapsulated in rubber.

The valve is standard with a sealed and grease packed buried service manual worm gear and a 2" square nut. Automatic actuation with floor stand or extended bonnet are also available.

Standard Features

- Internal and external epoxy coated, high strength ductile iron body and cover
- 100% port area, up to 53% less head loss than standard rectangular port plug valves
- Bi-directional zero leakage
- Fully rubber encapsulated ductile iron plug
- Shaft packing protected from ground contamination
- 316SS upper and lower shaft bearings
- Top and bottom lifting eyes and feet to facilitate handling and installation

Standard Materials

- Body and Cover Ductile Iron, ASTM A536 Gr 65-45-12
- Body Seat Weld Overlaid 95% Pure Nickel
- Plug Ductile Iron, ASTM A536 Gr 65-45-12
- Plug Coating Buna-N Rubber, Molded and Vulcanized to the Plug
- Shaft Bearings 316 Stainless Steel
- Thrust Bearings Aluminum Bronze
- External Fasteners 316 Stainless Steel
-

Corrosion Protection

- Standard: Internal and External PPG/Amerlok 400 2-Part Epoxy

Ordering Data

- Figure Number B517RF
- Size
- Connections (MJ)
- Actuation (Standard is 2" Operating Nut)
- Options/Accessories

Data Sheet B517RF.02A



Approvals & Certifications

- Fully complies with AWWA Standard C517

Non-Shock Working Water Pressure at up to 180F (82C)	
Figure Number	B517RF
Connections	Mechanical Joint (MJ) per AWWA/ANSI C111
Manual Operation	Buried Service Worm Gear with 2" Nut
Size	24" to 48"
Direct Seating Max Pressure	150 PSI
Reverse Seating Max Pressure	24" – 150 PSI, 30" to 48" – 100 PSI
Hydro Test	225 PSI

Data Sheet B517RF.02A

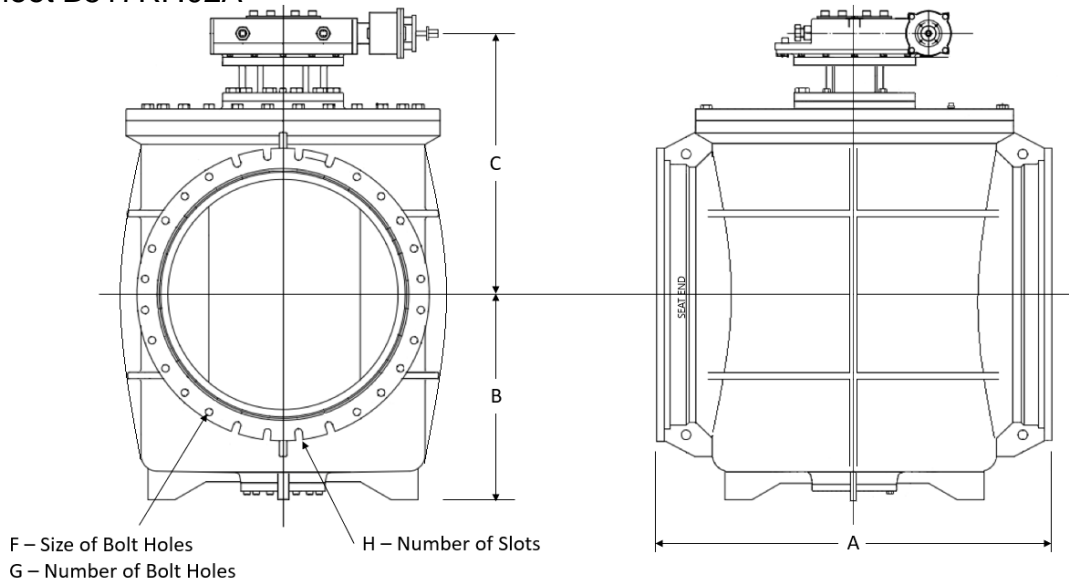

Installation Dimensions

SIZE	24"	30"	36"	42"	48"
A	42	51	60	72	84
B	20.7	26.6	30.7	37.4	42.3
C	28.0	35.2	40.1	50.0	54.7
F	7/8	1 1/8	1 1/8	1 3/8	1 3/8
G	12	12	16	20	24
H	4	8	8	8	8
WGT	2,510	4,975	7,775	14,175	20,145

Flow Coefficients

SIZE	24"	30"	36"	42"	48"
C_v	41,000	65,000	95,000	110,000	135,000
K	0.18	0.17	0.17	0.23	0.26

- Dimension C represents standard worm gear actuator
- Worm gear actuator can be rotated in 90-degree increments about valve centerline
- Consult factory for dimensions of valves with automatic actuators
- Dimensions in inches and weight in pounds and are approximate. Request certified drawings if critical.

