

# Figure 231-D, 232-D Increasing Size Lever & Spring Swing Check Valve

## Description

GA Industries Figures 231-D and 232-D are heavy duty, customizable swing check valves that utilize an adjustable spring assisted closure to minimize slam and hammer. In addition, the valve's outlet connection is expanded one or two sizes larger than the inlet connection which can eliminate the need for an increaser fitting on the pump discharge.

Normally installed in the discharge of a pump to prevent backflow when the pump is off-line, it opens smoothly at pump start and closes quickly and quietly upon pump shutdown.

These lever & spring check valves can be installed in a horizontal or vertical pipe without modification.

Figures 231-D and 232-D meet the design, materials of construction and testing required by AWWA C508 and is suitable for use with water or sewage.



## Product Features

- Heavy duty construction withstands rigors of pump station operation
- Expanded outlet connection can eliminate need for increaser fitting
- Full flow area when swung only 25° away from seat for low head loss and reduced pumping cost
- Replaceable rubber disc seat for tight seating at low and high pressure
- Lever & spring field convertible from standard right hand to left hand side

## Standard Materials

- Body & Disc Cast Iron, ASTM A126 Class B
- Cover Steel, ASTM A36
- Body Seat Stainless Steel, Type 316
- Disc Seat Buna-N
- Hinge Shaft Stainless Steel, Type 303
- External Fasteners Steel, A307, Zinc Plated
- Spring Steel
- Coating Internal and external Carboguard 891 NSF-61 certified 2-part epoxy

Non-Shock Working Water Pressure at up to 150F (66C)		
Figure No.	231-D Single Increasing	232-D Double Increasing
<b>Size (Inlet x Outlet)</b> <small>Inlet is Nominal Valve Size</small>	3" x 4" 4" x 6" 8" x 10" 10" x 12"	4" x 8" 6" x 10" 8" x 12"
<b>Flange</b>	ANSI B16.1 Class 125	
<b>Max Working Pressure</b>	200 PSI	
<b>Shell Test</b>	400 PSI	

## Approvals & Certifications

- NSF-61 Certified for Contact with Drinking Water
- NSF-372 Certified Lead Free (Max 0.25% Lead Content by Weighted Average)
- AIS and BABA Compliant

## Options

- Option 1D With Honeywell HDLS NEMA 1, 3, 4, 4X, 6, 6P, 12 & 13 DPDT Limit Switch
- Option CR With O-ring Shaft Seal Instead of Teflon Packing
- Option LH With Lever & Weight Factory Installed on Left Side Facing Inlet
- Option P3 With 316 SS Hinge Shaft, Disc Center Pin, Lock Nut and Washer, Shaft End Plate and External Fasteners
- Option S3 With Type 316 Stainless Steel Hinge Shaft (Included in Option P3)
- Option SE With 316 Stainless Steel External Fasteners (Included in Option P3)

## Ordering Data

- Figure Number (231-D or 232-D)
- Size
- Options and/or Accessories

Data Sheet 231-232.01D

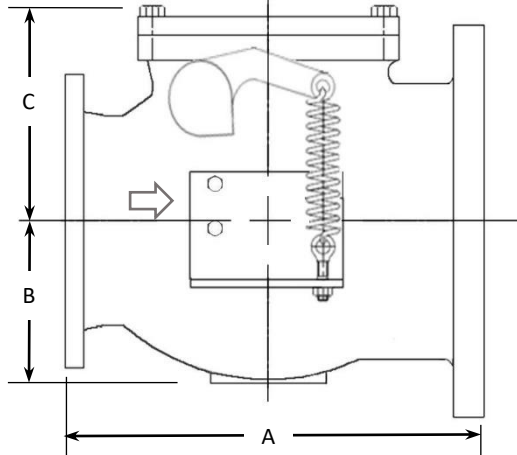
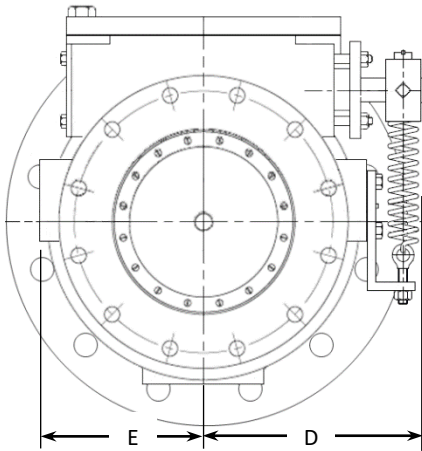

**Installation Dimensions**

	FIGURE 231-D SINGLE INCREASING					FIGURE 232-D DOUBLE INCREASING		
	3" x 4"	4" x 6"	6" x 8"	8" x 10"	10" x 12"	4" x 8"	6" x 10"	8" x 12"
A	12	13	17½	18	23	13½	18¾	22¼
B	7	8½	9	12	14	8½	9	12
C	5	5	6	9	9	5	6	9
D	10	11	12	14	15	11	12	14
E	5	5	7	8	9	5	7	8
WGT	120	175	250	350	525	180	270	390

**VERTICAL INSTALLATION**

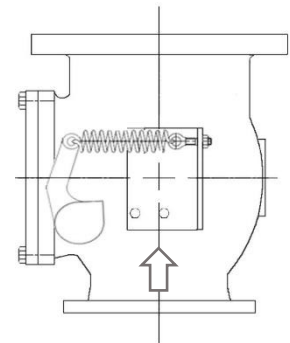

- Size is Inlet x Expanded Outlet
- Dimensions in inches, weight in pounds and are approximate. Request certified drawings if critical.

**Full Open Head Loss**

