

# Figures 251-D, 252-D Increasing Size Air Cushioned Swing Check Valve

## Description

GA Industries Figures 251-D and 252-D heavy duty, customizable swing check valves utilize an adjustable counterweight for rapid closure combined with a highly engineered air cushion chamber to provide non slam operation. In addition, the valve's outlet connection is expanded one or two sizes larger than the inlet connection which can often eliminate the need for an increaser fitting on the pump discharge.

Typically installed on the discharge of a pump to prevent backflow when the pump is off-line, it opens smoothly at pump start and closes quickly and quietly upon pump shutdown.

The Figures 251-D and 252-D meet the design, materials of construction and testing required by AWWA C508 and are suitable for use with water or sewage.



## Product Features

- Unique disc design affords 360-degree articulation for tight sealing under all pressure conditions
- Expanded outlet connection can eliminate need for increaser fitting
- Full flow area when swung only 25° away from seat for low head loss and reduced pumping cost
- Bolted cover allows access to all internal components
- Lever & weight and air cushion field convertible right hand to left hand side, and from horizontal to vertical installation

## Standard Materials

- Body & Disc Cast Iron, ASTM A126 Class B
- Cover Steel, ASTM A36
- Body Seat Stainless Steel, Type 316
- Disc Seat Buna-N
- Hinge Shaft Stainless Steel, Type 303
- Cushion Chamber Bronze
- External Fasteners Steel, A307, Zinc Plated
- Coating Internal and external NSF-61/600 certified 2-part epoxy

## Approvals & Certifications

- NSF-61 Certified for Contact with Drinking Water
- NSF-372 Certified Lead Free (Max 0.25% Lead Content by Weighted Average)
- AIS and BABA Compliant

## Options

- Option 1D With Honeywell HDLS NEMA 1, 3, 4, 4X, 6, 6P, 12 & 13 DPDT Limit Switch
- Option LH With Lever & Weight Factory Installed on Left Side Facing Inlet
- Option P3 With 316 SS Hinge Shaft, Disc Center Pin, Lock Nut and Washer, Shaft End Plate and External Fasteners
- Option S3 With Type 316 Stainless Steel Hinge Shaft (Included in Option P3)
- Option SE With 316 Stainless Steel External Fasteners (Included in Option P3)
- Option VI Configured for Vertical Flow Up Installation

## Ordering Data

- Figure Number (251-D or 252-D)
- Size
- Options and/or Accessories

Non-Shock Working Water Pressure at up to 150F (66C)		
Figure No.	251-D Single Increasing	252-D Double Increasing
Size (Inlet x Outlet) Inlet is Nominal Valve Size	3" x 4"	
	4" x 6"	4" x 8"
	6" x 8"	6" x 10"
	8" x 10"	8" x 12"
	10" x 12"	
Flange	ANSI B16.1 Class 125	
Max Working Pressure	200 PSI	
Shell Test	400 PSI	

Data Sheet 251-252.01F

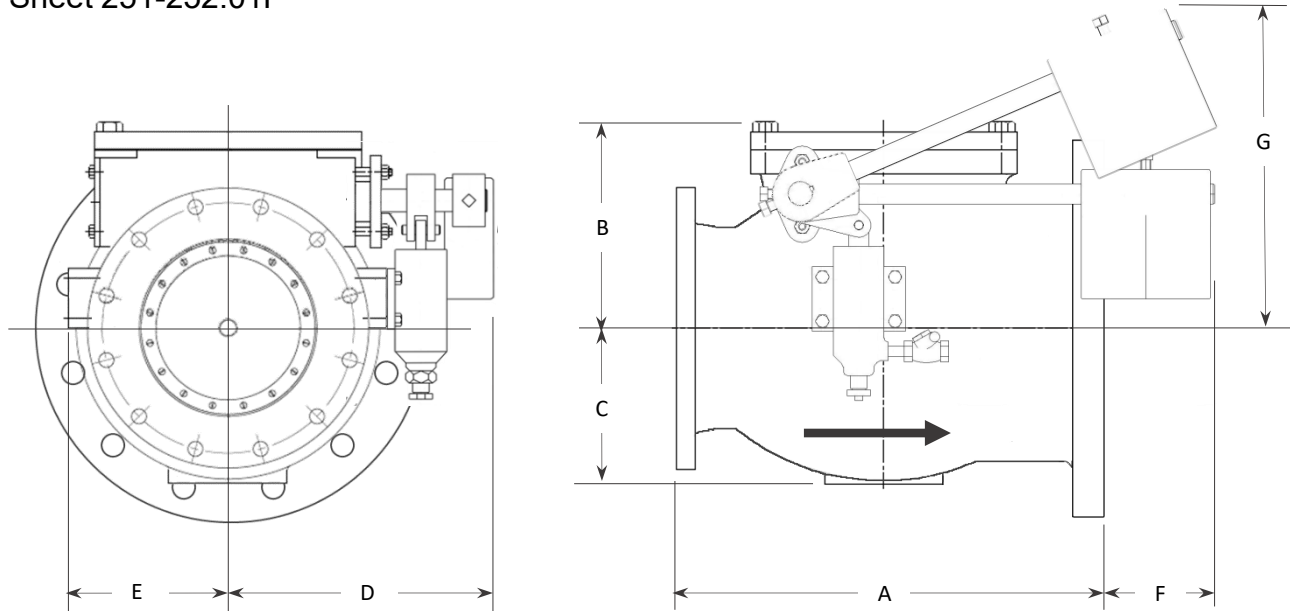

**Installation Dimensions**

	FIGURE 251-D SINGLE INCREASING					FIGURE 252-D DOUBLE INCREASING		
	3" x 4"	4" x 6"	6" x 8"	8" x 10"	10" x 12"	4" x 8"	6" x 10"	8" x 12"
A	12	13	17½	18	23	13½	18⅞	22¼
B	7	8½	9	12	14	8½	9	12
C	5	5	6	9	9	5	6	9
D	10	11	12	14	15	11	12	14
E	5	5	7	8	9	5	7	8
F	5	5	3	3	--	4½	1⅝	--
G	15	16	19	21	23	16	19	21
H	9¼	8½	10⅝	9	9	8½	10⅝	9
WGT	120	175	250	350	525	180	270	390

- Size in inlet x expanded outlet
- Dimension G is valve fully open, Dimensions F and H are valve fully closed
- Dimensions in inches, weight in pounds and are approximate. Request certified drawings if critical.

**Full Open Head Loss**

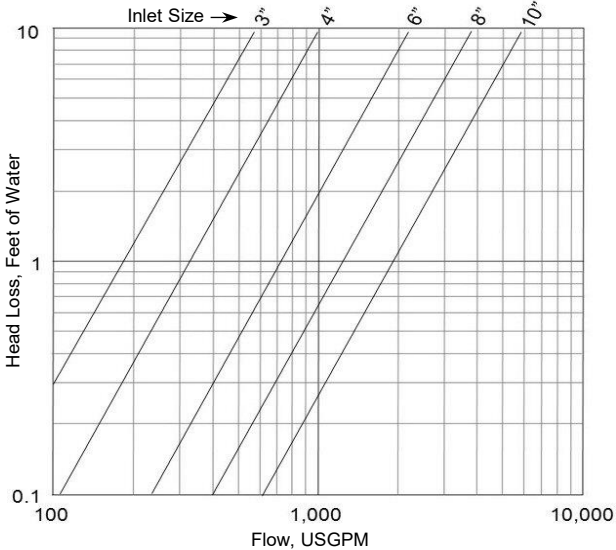

**VERTICAL INSTALLATION**

