

INSTALLATION, OPERATION AND MAINTENANCE MANUAL

Figures 4700-D, 4700-DC, 4700-U, 4700-UC Pilot-Operated Pressure Reducing & Sustaining Valves

Drawing D-1041 (Globe 2½” to 20”)

Drawing D-1383 (Angle 2½” to 20”)

SECTION 1 – 2½” to 20” Figure 4700 Pilot-Operated Pressure Reducing
Valve Instructions

SECTION 2 – 2½” to 10” Differential Piston Main Valve Instructions

SECTION 3 – 12” to 20” Differential Piston Main Valve Instructions

SECTION 4 – Figure 43 Reducing Pilot Instructions

SECTION 5 – Figure 667 Relief/Sustaining Pilot Instructions



234 Clay Avenue • Mars, PA 16046 USA
Telephone (724) 776-1020 • Fax (724) 776-1254
E-mail: info-ga@vag-group.com

Manual O&M-4700-2.5-20inch-43/667 Pilots 101821R1



WARNING: Cancer and Reproductive Harm – www.Prop65Warnings.ca.gov

Section 1

INSTALLATION, OPERATION AND MAINTENANCE MANUAL

Figures 4700-D, 4700-DC, 4700-U, 4700-UC Pilot-Operated Pressure Reducing & Sustaining Valves

Drawing D-1042 (Globe 2½” to 20”)

Drawing D-1383 (Angle 2½” to 20”)

TABLE OF CONTENTS

Introduction.....	1
Description of Operation	1
Receiving & Storage.....	1
Installation.....	1 & 2
Start-Up.....	2
Adjusting The Pressure Setting	2
Preventative Maintenance	3
Trouble Shooting.....	3 & 4
Repair Instructions	4
Replacement Parts	4
Warranty.....	4
Assembly Drawing/Component Location ..	4



234 Clay Avenue • Mars, PA 16046 USA
Telephone (724) 776-1020 • Fax (724) 776-1254
E-mail: info-ga@vag-group.com

Manual Number IOM-4700-2.5-20inch 1018821



WARNING: Cancer and Reproductive Harm – www.Prop65Warnings.ca.gov

INSTALLATION, OPERATION and MAINTENANCE

Figures 4700-D, 4700-DA, 4700-U, 4700-UA Pilot-Operated Pressure Reducing & Sustaining Valve

INTRODUCTION

This manual provides information to install, operate and maintain GA Industries pilot-operated pressure reducing and sustaining valves to ensure a long service life. The valve is ruggedly constructed to provide many decades of dependable service with minimal maintenance.

CAUTION

The valve is NOT recommended for use with toxic, corrosive, or flammable fluids.

The Shop Order (SO) Number, Figure Number, size, and pressure rating are stamped on a nameplate attached to the valve. Please refer to the SO number when ordering parts.

NOTE: This manual applies to GA Industries pressure reducing and sustaining valves with a Figure 43 reducing pilot that has a separate downstream pressure sensing line. For GA Industries 2½" to 8" pressure reducing & sustaining valves utilizing the Figure 43223 reducing pilot *without* a separate sensing line see manual IOM-Fig 4700-2.5-8inch-43223 Pilot.

DESCRIPTION OF OPERATION

Pressure reducing and sustaining valves sustain a minimum inlet pressure and limit the downstream pressure to a pre-set maximum.

Providing inlet pressure is above the pre-set minimum, the valve will reduce a higher, fluctuating inlet pressure to a lower, steady outlet pressure regardless of variations in demand.

Should inlet pressure fall to the pre-set minimum the valve will throttle to sustain the minimum inlet pressure and close if the inlet pressure falls below the minimum.

The valve consists of a differential piston main valve and a pilot system, pre-piped and factory installed on the main valve. The main valve consists of just one moving part – the piston – with the top of the piston being larger than the bottom. System pressure applied to the bottom of the piston provides an opening force. When system pressure is

simultaneously applied to the larger area on top of the piston, a greater closing force produced. Thus, applying system pressure to the top of the piston closes the valve while exhausting it from the top allows system pressure to lift the piston and open the valve.

The pilot system consists of a relief/sustaining pilot, reducing pilot, closing speed needle valve, wye strainer and pilot isolating valves. The relief/sustaining pilot senses pressure at the inlet side of the main valve. The reducing pilot senses the pressure at the outlet side of the main valve. See Page 5 for location of components.

Inlet pressure is constantly admitted to the top of the piston through the closing speed needle valve. The main valve opens when the inlet pressure is higher than the setting of the relief/sustaining pilot and the outlet pressure is lower than the setting of the reducing pilot.

Providing the inlet pressure is higher than the setting of the relief/sustaining pilot, the valve functions as a pressure reducing valve. The main valve opens until the flow through the valve matches demand at the downstream pressure set on the reducing pilot. When demand is zero the reducing pilot is closed, trapping system pressure on top of the piston holding the main valve closed. An increase in demand causes the downstream pressure to fall, opening the pilot and allowing water to flow off the top of the piston through the pilot faster than it's flowing onto the piston through the needle valve thereby lowering the pressure on top of the piston. Inlet pressure acting on the underside of the piston then lifts the piston and allows flow through the main valve.

As demand varies, the pilot will throttle the main valve as needed to maintain the downstream pressure at the desired pressure within a narrow deadband.

However, should inlet pressure fall to the setting of the relief/sustaining pilot it overrides the reducing pilot and throttles the main valve to sustain the minimum inlet pressure.

The main valve will close if the inlet pressure falls below the setting of the relief/sustaining pilot.

Figures 4700-DC and 4700-UC utilize a main valve with a “stop-check” feature that will close, independent of the pressure pilots, to prevent reverse flow should inlet pressure fall below outlet pressure

RECEIVING AND STORAGE

Inspect the valve upon receipt for damage during shipment. Carefully unload all valves to the ground without dropping.

Valves should remain in a clean, dry, and weather protected area until installed. After completion of shop testing the valve is drained of the test water but a small residual amount could remain so the valve should be protected from freezing during storage.

INSTALLATION

Figure Numbers suffixed with “D” indicate the valve has ANSI Class 125 flanged connections, Figure Numbers suffixed with “U” indicate the valve has ANSI Class 250 flanged connections.

GA Industries differential piston pressure reducing valves are typically supplied with a globe body main valve where the inlet and outlet connections in line. They can be supplied with an angle body main valve that have the inlet and outlet connections 90 degrees apart. Angle body pressure reducing valves are designated with an “A” (e.g., 4700-DA, 4700-UA).

Install the valve in the proper flow direction noting the “INLET” tag on the valve. The INLET is the high-pressure side of the valve.

The valve is configured to be installed in the orientation specified by the engineer. Consult the drawings of record to verify the valve is installed in the proper orientation.

Figures 4700-DC and 4700-UC with Stop-Check Piston should be installed with the bolted cover parallel to the floor/ground to ensure proper operation of the check feature.

Prior to installation ensure all debris, packing material or other foreign material has been removed from both ports.

If installed outdoors, below ground in a vault or in an unheated area, adequate freeze protection must be provided.

Adequate isolating valves should be installed between the valve and the pipeline or system to facilitate maintenance.

Pressure gauges should be installed on the inlet and outlet side of the valve to facilitate start-up and pressure adjustments.

The valve should be installed with sufficient clearance to permit maintenance and removal of internal components.

The valve is not designed to support adjacent equipment, piping loads should not be imposed on the valve and large valves should be properly supported. Ensure mating flanges are square and parallel to the valve flanges before tightening flange bolts.

Flat-faced flanged valves should be mated with flat-faced flanges and full-face gaskets. If ring gaskets are used the bolt material shall be ASTM A307 Grade B (or equivalent). Higher strength bolting should only be used with full-face gaskets.

Lower heavy valves using slings or chains around the valve body and/or the lifting eyes. **DO NOT LIFT BY THE EXTERNAL PILOT PIPING.** Lubricate the bolts or studs and insert around flange. Lightly tighten bolts until gaps are eliminated. Torque bolts in an alternating pattern in graduated steps. If leakage occurs wait 24 hours and re-torque the bolts but do not compress the gasket more than 50% or exceed bolt maximum torque rating.

START-UP

The valve generally does not require any calibration or adjustment prior to start-up. The sustained and reduced pressures are factory set at the pressures specified by the engineer and indicated on the tag affixed to the pilot.

Refer to Page 5 for the location of components.

The closing speed needle valve should be initially opened $\frac{1}{4}$ to $\frac{1}{2}$ turn from closed. Close the needle valve completely then turn the handwheel $\frac{1}{4}$ to $\frac{1}{2}$ turn counterclockwise.

All stop valves in the valve’s pilot system must be fully open.

NOTE: If the valve is being installed in an orientation that the main valve’s bolted cover is not parallel to the floor/ground, it’s recommended the main valve’s piston be filled with water before installation. This can be done by removing an unused pipe plug from the valve’s cover and filling the valve through a funnel. Replace the pipe plug before installing the valve.

After the valve has been installed and with the downstream isolating valve closed, slowly open the inlet isolating valve to introduce pressure to the valve. Air in the valve and pilot system should be bled before putting the valve into service. Loosen a pipe union at a high point in the pilot system so air can escape. Tighten the union after all the air has been vented.

The pressure reducing and sustaining valve is factory set at “zero flow.” Slowly open the downstream isolating valve. Providing the inlet pressure is higher than the setting of the relief/sustaining pilot, the main valve will open, allowing flow through the valve begins the downstream pressure will fall off a little from the

“zero flow” factory setting. Once open, the valve will maintain the downstream pressure within a narrow range as demand changes.

A slight and/or intermittent discharge of water from the main valve side vent tube is normal and has no effect on the valve’s operation.

ADJUSTING THE PRESSURE SETTING

The pressure reducing and sustaining valve has two pilots. The relief/sustaining pilot (Pilot A) determines the minimum pressure sustained at the valve inlet and the reducing pilot (Pilot B) determines the reduced pressure at the valve’s outlet. Both can be independently field adjusted within the range of the pilot’s installed spring.

If the required pressure setting is higher than the installed spring’s maximum setting, the spring or pilot must be changed.

Turning the pilot handwheel clockwise raises the set pressure, turning it counterclockwise lowers the set pressure.

GA Industries Figures 4700D and 4700-U in sizes 2½” to 16” are supplied with ½” pilots with either a 5-inch or 7-inch diaphragm, as measured by the outside diameter of the pilot. Larger sizes are supplied with 1” pilots with 7-inch diaphragm.

½” Pilot with 5-inch Diaphragm

SPRING COLOR	MAX PRESSURE SETTING	WIRE DIAMETER	CHANGE PER FULL TURN
White	20 PSI	0.250”	0.64 PSI
Green	45 PSI	0.313”	1.7 PSI
Black	110 PSI	0.375”	4.5 PSI
Red	155 PSI	0.438”	9.1 PSI
Yellow	250 PSI	0.500”	18.6 PSI
Blue	330 PSI	0.563”	36.0 PSI

½” Pilot with 7-inch Diaphragm

SPRING COLOR	MAX PRESSURE SETTING	WIRE DIAMETER	CHANGE PER FULL TURN
Yellow	10 PSI	0.219”	0.25 PSI
Green	20 PSI	0.250”	0.50 PSI
Black	30 PSI	0.313”	1.2 PSI
White	50 PSI	0.375”	2.3 PSI
Red	100 PSI	0.500”	7.2 PSI
Blue	125 PSI	0.563”	11.0 PSI

1” Pilot with 7-inch Diaphragm

SPRING COLOR	MAX PRESSURE SETTING	WIRE DIAMETER	CHANGE PER FULL TURN
Yellow	10 PSI	0.219”	0.50 PSI
Green	20 PSI	0.250”	0.55 PSI
Black	35 PSI	0.313”	1.3 PSI
White	55 PSI	0.375”	2.5 PSI
Red	110 PSI	0.500”	8.0 PSI
Blue	135 PSI	0.563”	12.0 PSI

PREVENTATIVE MAINTENANCE

No routine lubrication or adjustments are needed. The valve should be visually inspected once a month for the first 3 to 6 months after initial start-up to check for leaks and the wye-strainer should be flushed of collected debris.

Flushing the wye-strainer can be facilitated by installing a small ball or gate valve in place of the pipe plug in the bottom of the wye-strainer. Opening the valve while there is pressure in the system will “blow off” collected debris.

After the initial period, once every three (3) months the strainer should be flushed of collected debris as described above. Visually inspect for leaks around the indicator rod, side vent tube or pilot vent hole. If leakage is detected, see **TROUBLESHOOTING** to resolve.

WARNING

Personal injury may occur if the valve is disassembled while pressurized. Before attempting disassembly, follow appropriate lockout/tag out procedures to prevent accidental pressurization.

Once a year the valve should be isolated, depressurized and the wye-strainer screen removed and cleaned. At the same time the closing speed needle valve should be inspected. First, note the number of turns required to close it fully. Remove the needle valve bonnet and needle and inspect the needle for wear. Replace if needed. Clear needle valve seat of collected debris and reinstall the bonnet and needle. Open to the noted position.

TROUBLESHOOTING

SYMPTOM or PROBLEM	SOLUTION
Main valve will not open	
<ul style="list-style-type: none"> Inlet pressure below setting of relief/sustaining pilot 	This is normal if the inlet pressure is lower than the required minimum. If not, lower the setting of the relief/sustaining pilot to a lower pressure
<ul style="list-style-type: none"> Water cannot exhaust from top of piston 	Check status of stop valves in external pilot piping
<ul style="list-style-type: none"> Insufficient differential pressure 	Ensure inlet pressure is nominally 20% higher than the reduced pressure setting.
<ul style="list-style-type: none"> Vent tube blocked 	Ensure vent tube is open to atmosphere
<ul style="list-style-type: none"> Indicator rod packing too tight 	Turn indicator gland counterclockwise in quarter turn increments
Main valve will not close	
<ul style="list-style-type: none"> Inlet pressure cannot be applied to top of piston 	Check status of stop valve ahead of wye-strainer in external pilot piping
<ul style="list-style-type: none"> Wye-strainer clogged 	Flush strainer or remove screen to clear debris
<ul style="list-style-type: none"> Closing speed needle valve closed 	Turn handwheel counterclockwise ¼ turn
<ul style="list-style-type: none"> Debris in main valve 	Isolate the valve, remove pilot piping and valve cover, clear debris and inspect internal components for damage. Replace as needed
Main Valve “Hunts” (Cycles Up and Down)	
<ul style="list-style-type: none"> Closing speed needle valve open too far 	Slowly close (turn handwheel clockwise) until cycling stops/diminishes
<ul style="list-style-type: none"> Closing speed needle valve worn 	Replace
Leakage through main valve when closed	
<ul style="list-style-type: none"> Debris in valve 	Remove debris, inspect for damage
<ul style="list-style-type: none"> Worn or damaged seat ring 	Inspect, replace (See Repair Instructions)
Excessive leakage through vent tube (slight or intermittent leakage is normal)	
<ul style="list-style-type: none"> Worn piston and/or liner seals 	Replace (See Repair Instructions)
<ul style="list-style-type: none"> Vent tube loose or its threaded connection to liner not sealed 	Tighten and/or apply thread sealant. (See Repair Instructions)
Excessive leakage past indicator rod (slight or intermittent leakage is normal)	
<ul style="list-style-type: none"> Indicator packing worn or not sufficiently compressed 	Turn indicator gland clockwise one quarter to one half turn. DO NOT OVERTIGHTEN. If leakage does not stop, replace indicator packing.

REPAIR INSTRUCTIONS

Instructions for the inspection, troubleshooting and repair of the main valves utilized in the GA Industries Figure 4700-D and 4700-U pressure reducing valves are provided in the following publications:

2½” to 10” – IOM-DPMV2.5-10 (Latest Rev)

12” to 20” – IOM-DPMV12-20 (Latest Rev)

Instructions for the inspection, troubleshooting and repair of the ½” and 1” Figure 43 reducing pilots and Figure 667 relief/sustaining pilots utilized in the GA Industries Figure 4700-D and 4700-U pilot-operated pressure reducing and sustaining valves are provided in IOM-43P (Latest Rev) and IOM-667P (Latest Rev) respectively.

REPLACEMENT PARTS

Genuine replacement parts are available from your local GA Industries representative or from the factory:

VAG USA, LLC
 234 Clay Avenue
 Mars, PA 16046 USA
 Telephone: 724-776-1020
 Fax: 724-776-1254
 E-mail: quotes-ga@vag-group.com

Please have the nameplate data available when ordering parts.

WARRANTY:

The Warranty for GA Industries valves is included in our Terms and Conditions which can be found here: <https://gaindustries.com/terms>

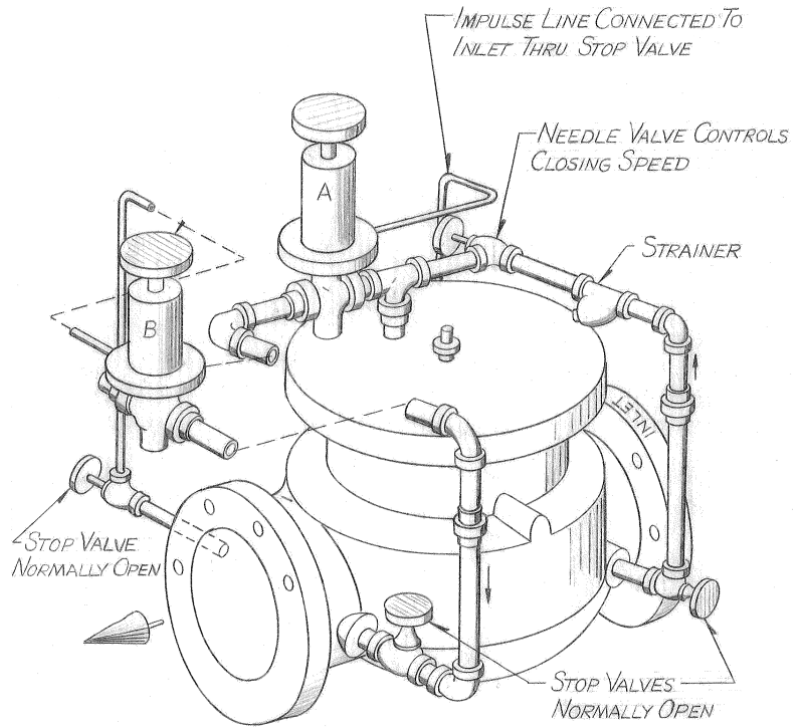

Figure 4700-D and 4700-U
Globe Body

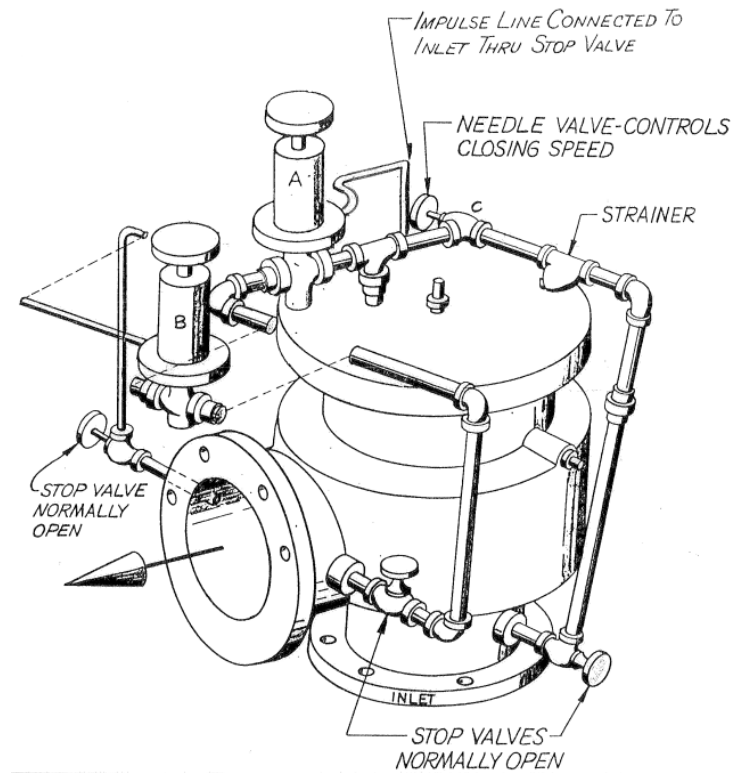

Figure 4700-DA and 4700-UA
Angle Body

Section 2

OPERATION AND MAINTENANCE MANUAL

2½” to 10” Differential Piston Main Valves

Drawings G-1035, G-1036, G-1037, G-1041, G-1047, G-1051,
D-1028 and D-1161

TABLE OF CONTENTS

Introduction	1
Types of Differential Piston.....	1
Receiving & Storage	2
Installation	2
Valve Construction	2
Start-Up	2
Preventive Maintenance	2
Trouble Shooting	3
Main Valve Repair Instructions	2 to 5
Replacement Parts	5
Repair Kits	5
Warranty	5
Assembly Drawing/Parts Location....	6 & 7



234 Clay Avenue • Mars, PA 16046 USA
Telephone (724) 776-1020 • Fax (724) 776-1254
E-mail: info-ga@vag-group.com

Manual Number IOM-DPMV-2.5-10inch 041621



WARNING: Cancer and Reproductive Harm – www.Prop65Warnings.ca.gov

INSTALLATION, OPERATION and MAINTENANCE

2½” to 10” Differential Piston Main Valve

INTRODUCTION

This manual provides information about the operation and proper maintenance of standard GA Industries differential piston main valves. The main valve is an integral part of all GA Industries differential piston pilot-operated control valve. The valve is ruggedly constructed to provide many decades of dependable service with minimal maintenance.

CAUTION

The valve is NOT recommended for use with toxic, corrosive, or flammable fluids.

The Shop Order (SO) Number, Figure Number, size and pressure rating are stamped on a nameplate attached to the valve. Please refer to the SO number when ordering parts.

DESCRIPTION OF OPERATION

The operation of the main valve is controlled by the pilot system which automatically closes, opens or throttles the main valve. The main valve consists on one moving part, the piston. Applying inlet pressure to the underside of the piston creates an opening force but simultaneously applying it to the larger area on top of the piston creates a greater closing force. Thus, applying inlet pressure to the top of the piston closes the main valve (Figure 1) while exhausting it from the top opens the main valve (Figure 2).

A regulating pilot controls the pressure applied to the top of the piston so that the opening and closing forces are balanced and the main valve is in a partially open, “throttled” position to control pressure level or flow (Figure 3).

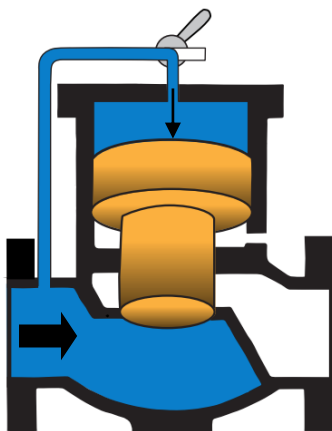

Figure 1. Valve Closed

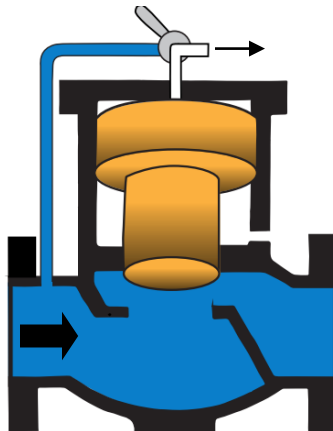

Figure 2. Valve Open

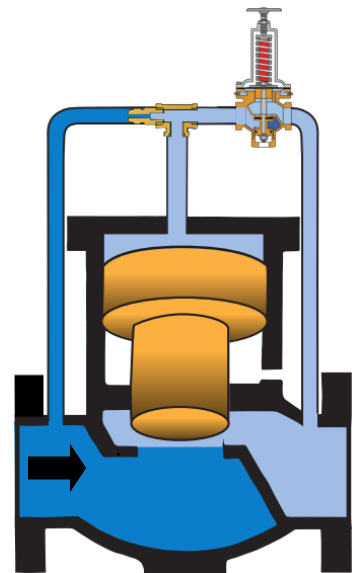

Figure 3. Valve Throttling

TYPES OF DIFFERENTIAL PISTON MAIN VALVES

There are two basic types of differential piston main valves: Water Service and Reducing Service. While there are exceptions, water service main valves are typically used in GA Industries pilot-operated control valves that perform an “open/close” (non-throttling) function (e.g., pump control, altitude, surge relief, solenoid) and reducing service main valves are typically used in GA Industries pilot-operated control

valves that regulate or throttle (e.g., pressure reducing, pressure sustaining, flow control). The parts for water service main valves are different than for reducing service so it's important to know the type of main valve. To aid in identifying, Table 1 lists the diameter of the top of the piston or the factory can identify which type by the valve's serial (SO) number

Table 1 Top of Piston Diameter

SIZE	Water Service	Reducing Service
2½"	4.25"	3.50"
3"	4.25"	3.50"
4"	5.63"	4.63"
6"	8.00"	6.75"
8"	10.50"	8.75"
10"	13.00"	10.75"

Most GA Industries differential piston main valves incorporate a 1-piece piston. Some main valves are supplied with optional 2-piece "stop-check" piston (Figure 4). If the valve is open and there is a pressure reversal, the bottom part of the piston (the "baffle") drops and checks to prevent back flow through the valve.

The "stop-check" piston can be supplied in both water service and reducing service main valves.

Repair procedures and parts (except for the piston, baffle, and indicator rod) are the same whether a 1-piece or 2-piece piston.



Figure 4

RECEIVING AND STORAGE

Inspect the valve upon receipt for damage during shipment. Carefully unload all valves to the ground without dropping.

Valves should remain in a clean, dry and weather protected area until installed. After completion of shop testing the valve is drained of the test water but a small residual amount could remain so the valve should be protected from freezing during storage.

INSTALLATION

Figure Numbers suffixed with "D" indicate the valve has ANSI Class 125 flanged connections, Figure Numbers suffixed with "U" indicate the valve has ANSI Class 250 flanged connections.

GA Industries differential piston globe body main valves have the inlet and outlet connections in line while angle body main valves have the inlet and outlet connections 90 degrees apart.

Install the valve in the proper flow direction noting the "INLET" tag on the valve.

The valve is configured to be installed in the orientation specified by the engineer. Consult the drawings of record to verify the valve is installed in the proper orientation.

Prior to installation ensure all debris, packing material or other foreign material has been removed from both ports.

If installed outdoors, below ground in a vault or in an unheated area, adequate freeze protection must be provided.

Adequate isolating valves should be installed between the valve and the pipeline or system to facilitate maintenance.

The valve should be installed with sufficient clearance to permit maintenance and removal of internal components.

The valve is not designed to support adjacent equipment, piping loads should not be imposed on the valve and large valves should be properly supported. Ensure mating flanges are square and parallel to the valve flanges before tightening flange bolts.

Flat-faced flanged valves should be mated with flat-faced flanges and full-face gaskets. If ring gaskets are used the bolt material shall be ASTM A307 Grade B (or equivalent). Higher strength bolting should only be used with full-face gaskets.

Lower heavy valves using slings or chains around the valve body and/or the lifting eyes. DO NOT LIFT BY THE EXTERNAL PILOT PIPING. Lubricate the bolts or studs and insert around flange. Lightly tighten bolts until gaps are eliminated. Torque bolts in an alternating pattern in graduated steps. If leakage occurs wait 24 hours and re-torque the bolts but do not compress the gasket more than 50% or exceed bolt maximum torque rating.

MAIN VALVE CONSTRUCTION

The standard valve has a flanged cast iron body with a bolted cover. The piston and liner are made from bronze. The piston has a replaceable rubber seat, held in place by a brass or stainless steel follower ring and stainless steel screws. A brass or stainless steel visual position indicator is attached to the piston and extends through the valve cover through a packing gland. A brass or stainless steel vent tube protrudes from the side of the main valve.

Refer to Pages 5 to 7 for parts identification and location for each type of main valve.

START-UP

Refer to the Installation, Operation and Maintenance Manual for the start-up procedure applicable to the pilot-operated control valve being installed.

PREVENTATIVE MAINTENANCE

The differential piston main valve does not require routine lubrication or adjustments. After the initial start-up, periodic visual inspection is recommended.

Perform any additional preventative maintenance procedures as recommended in the Installation, Operation and Maintenance Manual for the pilot-operated control valve being installed.

TROUBLESHOOTING

SYMPTOM or PROBLEM	SOLUTION
Main valve will not open	
<ul style="list-style-type: none"> • Water cannot exhaust from top of piston 	Check status of manual valves and electrical connection to solenoids (if any) in external pilot piping
<ul style="list-style-type: none"> • Insufficient inlet pressure 	Ensure inlet isolating valve is open and there is at least 5 to 10 PSI inlet pressure present. Small sizes require 10 PSI, minimum decreases with size.
<ul style="list-style-type: none"> • Vent tube blocked 	Ensure vent tube (22) is open to atmosphere
<ul style="list-style-type: none"> • Indicator rod packing too tight 	Turn indicator gland (17) counterclockwise in quarter turn increments
Main valve will not close	
<ul style="list-style-type: none"> • Inlet pressure cannot be applied to top of piston 	Check status of manual valves and electrical connection to solenoids (if any) in external pilot piping
<ul style="list-style-type: none"> • Wye-strainer clogged 	Clean strainer
Leakage through main valve when closed	
<ul style="list-style-type: none"> • Debris in valve 	Remove debris, inspect for damage
<ul style="list-style-type: none"> • Worn or damaged seat ring (10) 	Inspect, replace
Excessive leakage through vent tube (slight or intermittent leakage is normal)	
<ul style="list-style-type: none"> • Worn piston cup (4) and/or liner cup (7) 	Replace
<ul style="list-style-type: none"> • Vent tube (22) loose or its threaded connection to liner (3) not sealed 	Connection into liner (3) must be leak tight. Tighten and/or apply thread sealant.
Excessive leakage past indicator rod (slight or intermittent leakage is normal)	
<ul style="list-style-type: none"> • Indicator packing (18) worn or not sufficiently compressed 	Turn indicator gland (17) clockwise one quarter to one half turn. DO NOT OVERTIGHTEN. If leakage does not stop, replace indicator packing.

REPAIR PROCEDURES

GA Industries differential piston main valves are fully serviceable and repairable while the body remains bolted in the line. No special tools are required for normal repair. Due to the weight of the internal components, servicing large valves requires overhead lifting equipment.

Special care must be utilized when servicing differential piston main valves when installed such that the piston is in a horizontal position. Service can be more easily performed if large valves installed in this manner are first removed from the line.

Repair kits are available (see REPAIR KITS) and should be on hand before starting any repairs.

The valve should be disassembled only to the point necessary to perform the repair.

These repair procedures apply only to the main valve. External pilot piping should be removed prior to undertaking disassembly of the main valve. Adequate unions are provided in the control piping to facilitate removal.

CAUTION

Repairs should be conducted by skilled technicians who have read all instructions and are familiar with the equipment and associated drawings. Follow all safety procedures.

WARNING

Before starting repairs, ensure valve is isolated from the system and properly locked out and tagged to prevent accidental pressurization. Completely depressurize the valve before commencing work.

INSTALLING A 2½" to 10" REPAIR KIT

1. Remove indicator gland (17) and indicator packing (18)
2. Scribe or mark an alignment line on the OD of the cover and the top flange of the valve body to ensure cover is properly aligned during assembly
3. Remove cover bolts/nuts (14)
4. Remove cover (13) lifting straight up to avoid damaging or bending the indicator rod (16)
5. Remove cover O-ring (32)
6. Loosen indicator rod lock nut (20) and remove indicator rod (16).
7. Remove piston (2). DO NOT use indicator rod to pull out the piston. If necessary, remove indicator rod bushing (19) and install 5/8-11 eyebolt to lift piston out of the valve.
8. Remove the piston U-cup (4A)
9. Remove the seat ring (10) by removing the follower screws (12) and follower (12).
10. Reach inside the liner and remove the liner U-cup (7A)
11. Using very fine wet or dry emery cloth, sand the large ID of the liner and the small OD of the piston to shiny metal. Inspect for deep scoring or gouges on those surfaces that cannot be polished out. Consult factory for evaluation if unsure.

12. Install new liner U-cup ensuring the lips are pointing into the valve. Apply a very light coating of lightweight lubricant such as petroleum jelly.
13. Replace seat ring (10), follower ring (11) and screws (12) and tighten. Do not over-tighten to the point where the seat ring or the follower ring deforms.
 - a. Reducing service pistons: trim any rubber that extrudes beyond the small OD of the piston with a sharp utility type razor knife.
14. Install the new piston U-cup (4A) ensuring the lips are pointed toward the large diameter end of the piston. Apply a very light coating of lightweight lubricant such as petroleum jelly.
15. Apply a thin coating of lubricant to the large ID of the liner and the small OD of the piston.
16. Install the piston being careful not to damage the cups.
17. Install the indicator rod bushing (19). Clean and polish the indicator rod (16) with very fine emery cloth and install with indicator rod lock nut (20). Tighten lock nut.
18. Install cover new O-ring (32).
19. Align cover (13) and lower over indicator rod (16) *being careful not to bend the rod. Install cover bolt/nuts (14) and tighten in alternating pattern.*
20. Install new indicator packing (18) by wrapping it around the indicator rod and tamping until 2 or 3 threads are exposed. Cut off excess.
21. Install indicator gland (17) and tighten to compress packing only until resistance is felt. **DO NOT OVERTIGHTEN.** Packing compression can be adjusted once pressure has been introduced.
22. If desired, remove vent tube gland (23) and vent tube packing (24). **DO NOT LOOSEN OR REMOVE** vent tube (22). Replace packing as in step 20 above. Install vent tube gland (23) and tighten to compress packing.
23. Replace pilot piping, slowly introduce pressure to the valve and check for leaks. Tighten indicator rod gland only as much as needed to stop leakage.

LINER REMOVAL & INSTALLATION

1. Mark a line across top of liner and the top of the valve body to ensure the liner is properly aligned when installed.
2. Remove the vent tube gland (23), packing (24) and unscrew the vent tube (22). **DO NOT DAMAGE THE VENT TUBE SEALING SURFACE.**
3. Reach inside the liner (3) through the V-ports and pull up while slightly rotating. In the unlikely event the liner cannot be extracted from the valve body in this manner, follow steps 3a through 3h. Otherwise, proceed to step 4.
 - a. Refer to Figure 5.
 - b. The "lower bar" is a steel bar approximately 1" x 1/2" x long enough to be inserted through opposite V-ports and engage the liner. It should be drilled and tapped 5/8"-11 at its center.
 - c. The "upper bar" is a steel bar the same size as the lower bar but with a length equal to the OD

of the valve's top flange. It should be drilled through 11/32" at its center.

- d. Support the upper bar on wooden blocks positioned just outside the OD of the liner.
- e. Insert a piece of 5/8"-11 all-thread through the upper bar and thread into the lower bar. It should be long enough to extend 1 to 2 inches beyond the upper bar.
- f. Install two 5/8"-11 hex nuts on the all thread and turn both nuts clockwise until resistance is felt.
- g. Continue to slowly turn the nuts to "jack" the liner outward. After a few turns the liner should "pop" at which time it can be removed.
- h. Note the liner in some 8" and 10" valves is in two pieces, a liner (3) and seat crown (21). Both pieces will be extracted using this method.

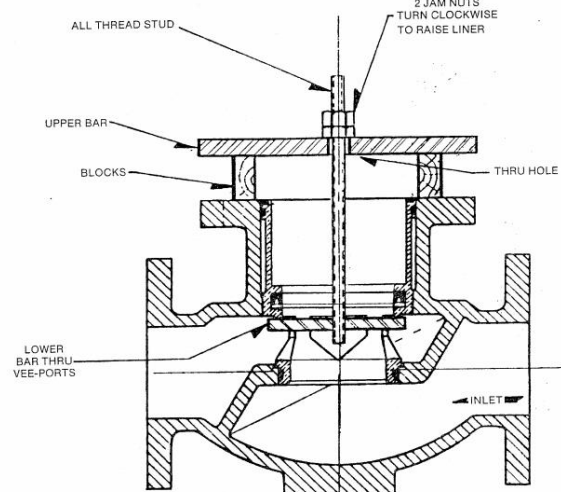

Figure 5

4. Once liner is extracted, remove top (33) and lower (35) liner O-rings.
5. Using very fine wet or dry emery cloth, sand the liner ID to shiny metal. Inspect for deep scoring or gouges that cannot be polished out. Consult factory for evaluation if unsure. Should a new liner be required, see **INSTALLING A NEW LINER**
6. Before installing the liner (and seat crown), lubricate the O-ring grooves and the top (33) and lower (35) O-rings and install in the appropriate grooves.
7. Clean and lubricate the areas of the valve body where the O-rings will seal.
8. Install the liner (3) so that it aligns with the mark, being careful not to damage the O-rings. If 2-piece liner, first install seat crown (21) then the liner (3).
9. The top of the liner should be flush with the top of the valve body. A mallet or wooden block can be used to bump the liner into position.
10. Apply pipe sealant or tape to the threads on one end of the vent tube (22) and thread into the liner. Tighten to a leak tight joint.

11. Install vent tube packing (24) and gland (23) and tighten to compress packing.

INSTALLING A NEW LINER

New liners are not drilled and tapped to accept the vent tube. Follow these instructions to ensure the liner is properly aligned before drilling/tapping.

1-Piece Liner

1. Locate the raised boss on the OD of the liner, compare to old liner
2. Install liner (3) without any O-rings in the valve body ensuring it is flush with the top of the valve body. Center the liner's boss on the vent tube hole in the side of the valve body.
3. Loosely install the vent tube gland (23) and slide in the vent tube (22). Insert a center punch through the vent tube and punch a mark in the liner.
4. Make an alignment mark across the liner and the top flange of the valve body
5. Remove the vent tube (22), gland (23) and liner (3).
6. Tap drill the liner 11/32" centered on the punch mark and tap 1/8" NPT.
7. Install liner in body and loosely screw in the vent tube and gland. If everything fits, remove gland, vent tube and liner and proceed with reassembly.

2-Piece Liner

1. There is no raised boss on the 2-piece liner
2. Install seat crown (21) and liner (3) without any O-rings in the valve body ensuring the liner is flush with the top of the valve body.
3. Loosely install the vent tube gland (23) and slide in the vent tube (22). Insert a center punch through the vent tube and punch a mark in the liner.
4. Make an alignment mark across the liner and the top flange of the valve body
5. Remove the vent tube (22), gland (23) and liner (3).
6. Tap drill the liner 11/32" centered on the punch mark and tap 1/8" NPT.
7. Install liner in body and loosely screw in the vent tube and gland. If everything fits, remove gland, vent tube and liner and proceed with reassembly.

REPLACEMENT PARTS

Genuine replacement parts are available from your local GA Industries representative or from the factory:

VAG USA, LLC
 234 Clay Avenue
 Mars, PA 16046 USA
 Telephone: 724-776-1020
 Fax: 724-776-1254
 E-mail: quotes-ga@vag-group.com

Please have the nameplate data available when ordering parts.

REPAIR KITS

The below Soft Goods Repair Kits are applicable to 2½" to 10" GA Industries differential piston main valves with a serial number 800000 or higher. The kits contain part numbers 4A, 7A, 10, 18, 24, 32, 33 and 35.

Reducing Service Kits

Size	Kit Number	Part Number
2½"	GA3R	2-80-23000-007
3"	GA3R	2-80-23000-007
4"	GA4R	2-80-23000-009
6"	GA6R	2-80-23000-012
8"	GA8R	2-80-23000-015
10"	GA10R	2-80-23000-004

Water Service Kits

Size	Kit Number	Part Number
2½"	GA3W	2-80-23000-008
3"	GA3W	2-80-23000-008
4"	GA4W	2-80-23000-010
6"	GA6W	2-80-23000-014
8"	GA8W	2-80-23000-016
10"	GA10W	2-80-23000-005

All other parts are ordered separately.

Consult factory for valves with lower serial numbers.

PARTS LIST

Refer to Figures 6, 7, 8 and 9 for parts location.

Item	Part Name
1	Body
2	Piston
2a	Baffle
3	Liner
4a	Piston U-Cup
7a	Liner U-Cup
10	Seat Ring
12	Seal Ring Follower Screws
14	Cover Bolts/Nuts
16	Indicator Rod
17	Indicator Gland
18	Indicator Packing
19	Indicator Bushing
20	Indicator Lock Nut
22	Vent Tube
23	Vent Tube Gland
24	Vent Packing
32	Cover O-Ring
33	Top Liner O-Ring
35	Lower Liner O-Ring

WARRANTY:

The Warranty for GA Industries valves is included in our Terms and Conditions which can be found here: <https://gaindustries.com/terms>

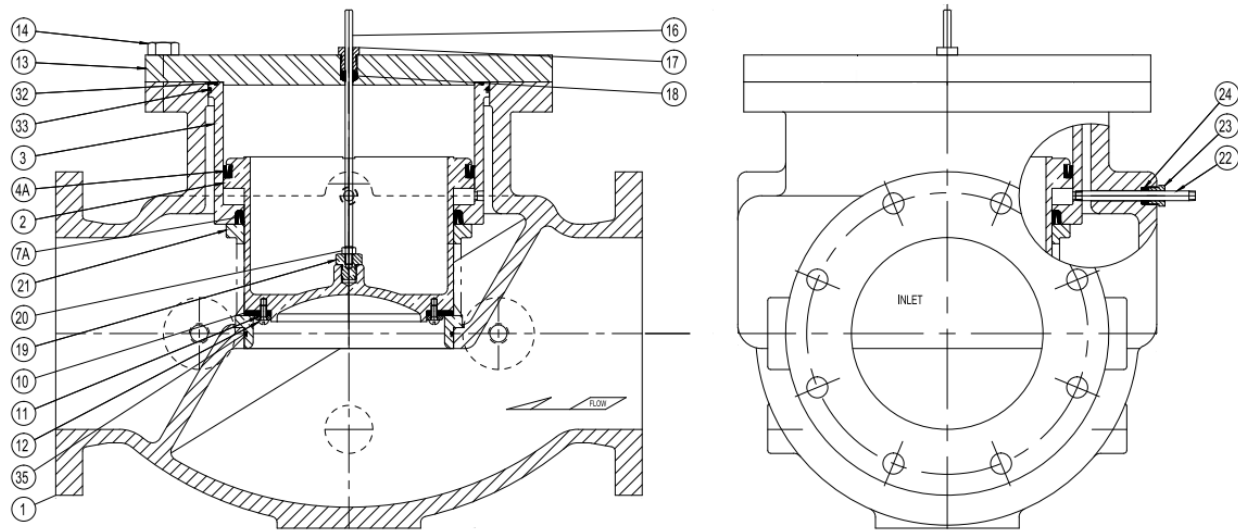

Figure 6 Globe Body

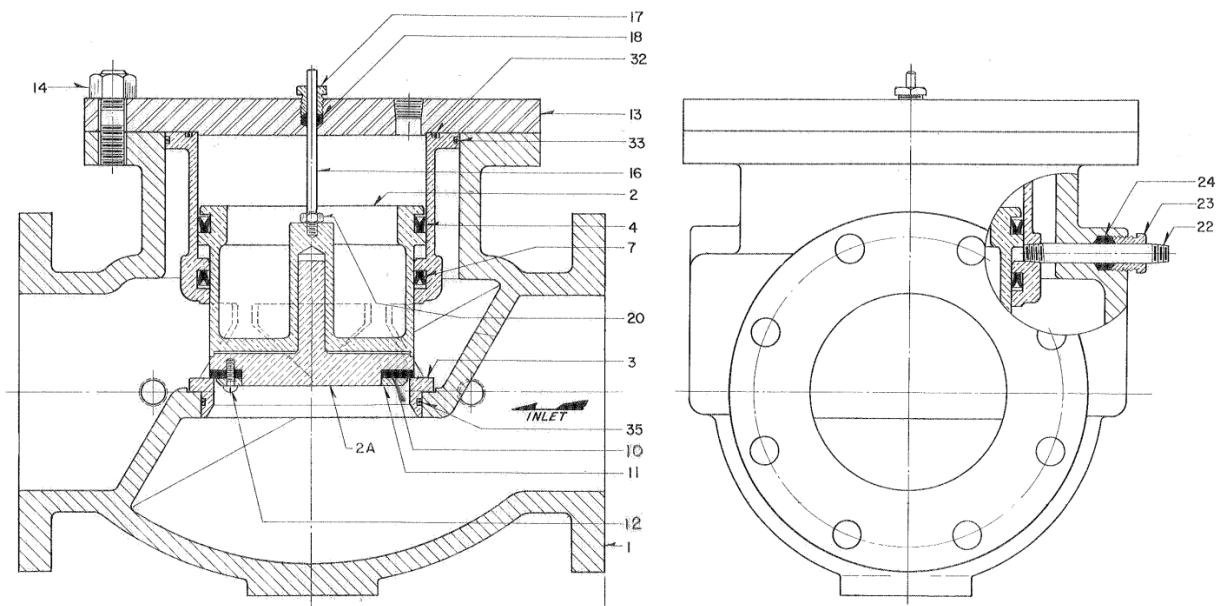

Figure 7 Globe Body, Stop Check

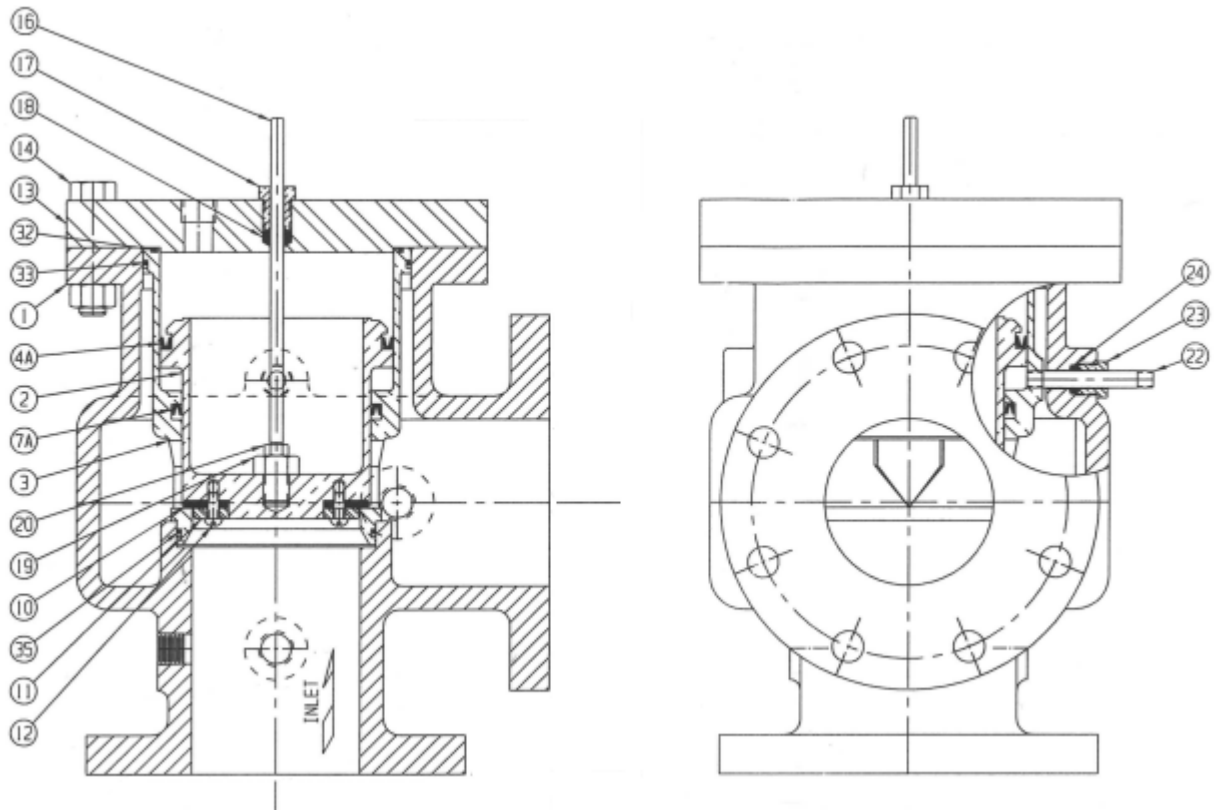

Figure 8 Angle Body

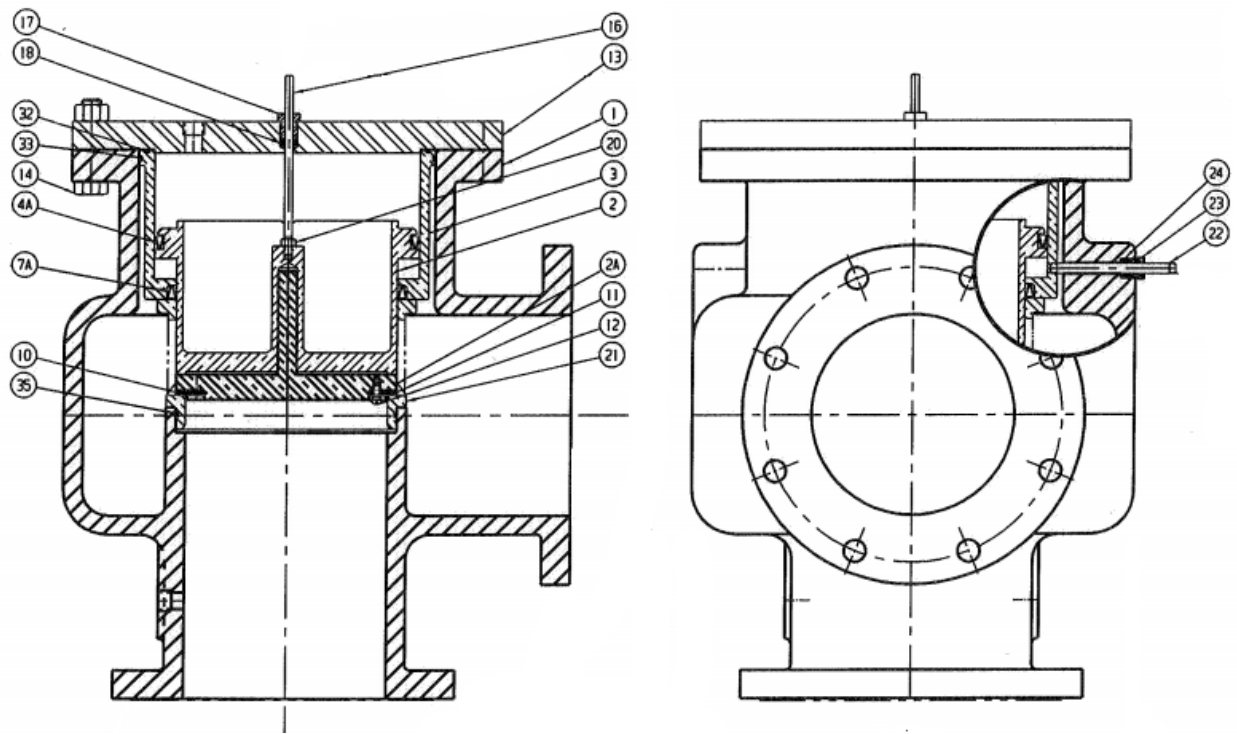

Figure 9 Angle Body, Stop Check

Section 3

OPERATION AND MAINTENANCE MANUAL

12” to 20” Differential Piston Main Valves

Drawings D-1027, D-1036, G-1031, G-1052, G-1054, G-1064

TABLE OF CONTENTS

Introduction	1
Types of Differential Piston.....	1
Receiving & Storage	2
Installation	2
Valve Construction	2
Start-Up	2
Preventive Maintenance	2
Trouble Shooting	3
Main Valve Repair Instructions	2 to 5
Replacement Parts	5
Repair Kits	5
Warranty	5
Assembly Drawing/Parts Location....	6 & 7



234 Clay Avenue • Mars, PA 16046 USA
Telephone (724) 776-1020 • Fax (724) 776-1254
E-mail: info-ga@vag-group.com

Manual Number IOM-DPMV-12-20inch 073121 (Rev 1)



WARNING: Cancer and Reproductive Harm – www.Prop65Warnings.ca.gov

INSTALLATION, OPERATION and MAINTENANCE

12" to 20" Differential Piston Main Valve

INTRODUCTION

This manual provides information about the operation and proper maintenance of standard GA Industries differential piston main valves. The main valve is an integral part of all GA Industries differential piston pilot-operated control valve. The valve is ruggedly constructed to provide many decades of dependable service with minimal maintenance.

CAUTION

The valve is NOT recommended for use with toxic, corrosive, or flammable fluids.

The Shop Order (SO) Number, Figure Number, size and pressure rating are stamped on a nameplate attached to the valve. Please refer to the SO number when ordering parts.

DESCRIPTION OF OPERATION

The operation of the main valve is controlled by the pilot system which automatically closes, opens or throttles the main valve. The main valve consists on one moving part, the piston. Applying inlet pressure to the underside of the piston creates an opening force but simultaneously applying it to the larger area on top of the piston creates a greater closing force. Thus, applying inlet pressure to the top of the piston closes the main valve (Figure 1) while exhausting it from the top opens the main valve (Figure 2).

A regulating pilot controls the pressure applied to the top of the piston so that the opening and closing forces are balanced and the main valve is in a partially open, "throttled" position to control pressure level or flow (Figure 3).

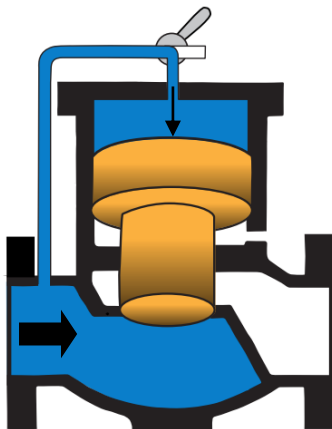

Figure 1. Valve Closed

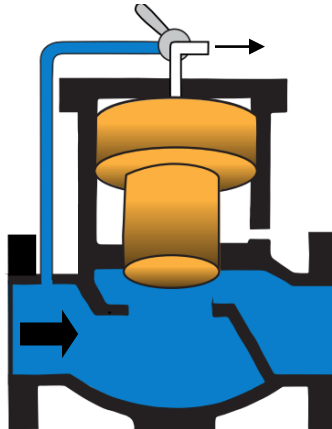

Figure 2. Valve Open

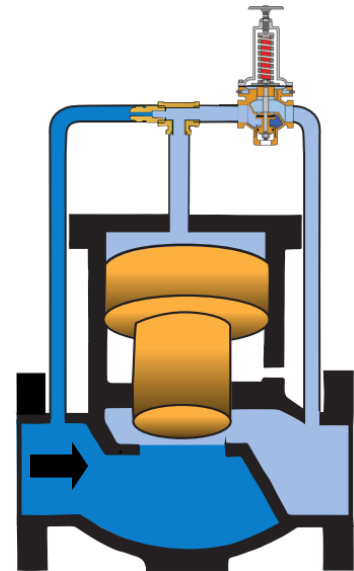

Figure 3. Valve Throttling

TYPES OF DIFFERENTIAL PISTON MAIN VALVES

There are two basic types of differential piston main valves: Water Service and Reducing Service. While there are exceptions, water service main valves are typically used in GA Industries pilot-operated control valves that perform an "open/close" (non-throttling) function (e.g., pump control, altitude, surge relief, solenoid) and reducing service main valves are typically used in GA Industries pilot-operated control

valves that regulate or throttle (e.g., pressure reducing, pressure sustaining, flow control). The parts for water service main valves are different than for reducing service so it's important to know the type of main valve.

To aid in identifying, Table 1 lists the diameter of the top of the piston or the factory can identify which type by the valve's serial (SO) number

Table 1 Top of Piston Diameter

SIZE	Water Service	Reducing Service
12"	15"	12.75"
14"	19"	15"
16"	21.75"	17"
18"	24.75"	21.25"
20"	24.75"	21.25"

Most GA Industries differential piston main valves incorporate a 1-piece piston. Some main valves are supplied with optional 2-piece "stop-check" piston (Figure 4). If the valve is open and there is a pressure reversal, the bottom part of the piston (the "baffle") drops and checks to prevent back flow through the valve.

The "stop-check" piston can be supplied in both water service and reducing service main valves.

Repair procedures and parts (except for the piston, baffle, and indicator rod) are the same whether a 1-piece or 2-piece piston.



Figure 4

RECEIVING AND STORAGE

Inspect the valve upon receipt for damage during shipment. Carefully unload all valves to the ground without dropping.

Valves should remain in a clean, dry, and weather protected area until installed. After completion of shop testing the valve is drained of the test water but a small residual amount could remain so the valve should be protected from freezing during storage.

INSTALLATION

Figure Numbers suffixed with "D" indicate the valve has ANSI Class 125 flanged connections, Figure Numbers suffixed with "U" indicate the valve has ANSI Class 250 flanged connections.

GA Industries differential piston globe body main valves have the inlet and outlet connections in line while angle body main valves have the inlet and outlet connections 90 degrees apart.

Install the valve in the proper flow direction noting the "INLET" tag on the valve.

The valve is configured to be installed in the orientation specified by the engineer. Consult the drawings of record to verify the valve is installed in the proper orientation.

Prior to installation ensure all debris, packing material or other foreign material has been removed from both ports.

If installed outdoors, below ground in a vault or in an unheated area, adequate freeze protection must be provided.

Adequate isolating valves should be installed between the valve and the pipeline or system to facilitate maintenance.

The valve should be installed with sufficient clearance to permit maintenance and removal of internal components.

The valve is not designed to support adjacent equipment, piping loads should not be imposed on the valve and large valves should be properly supported. Ensure mating flanges are square and parallel to the valve flanges before tightening flange bolts.

Flat-faced flanged valves should be mated with flat-faced flanges and full-face gaskets. If ring gaskets are used the bolt material shall be ASTM A307 Grade B (or equivalent). Higher strength bolting should only be used with full-face gaskets.

Lower heavy valves using slings or chains around the valve body and/or the lifting eyes. DO NOT LIFT BY THE EXTERNAL PILOT PIPING. Lubricate the bolts or studs and insert around flange. Lightly tighten bolts until gaps are eliminated. Torque bolts in an alternating pattern in graduated steps. If leakage occurs wait 24 hours and re-torque the bolts but do not compress the gasket more than 50% or exceed bolt maximum torque rating.

MAIN VALVE CONSTRUCTION

The standard valve has a flanged cast iron body with a bolted cover. The piston and liner are made from bronze. The piston has a replaceable rubber seat, held in place by a brass or stainless steel follower ring and stainless steel screws. A brass or stainless steel visual position indicator is attached to the piston and extends through the valve cover through a packing gland. A brass or stainless steel vent tube protrudes from the side of the main valve.

Refer to Pages 5 to 7 for parts identification and location for each type of main valve.

START-UP

Refer to the Installation, Operation and Maintenance Manual for the start-up procedure applicable to the pilot-operated control valve being installed.

PREVENTATIVE MAINTENANCE

The differential piston main valve does not require routine lubrication or adjustments. After the initial start-up, periodic visual inspection is recommended.

Perform any additional preventative maintenance procedures as recommended in the Installation, Operation and Maintenance Manual for the pilot-operated control valve being installed.

TROUBLESHOOTING

SYMPTOM or PROBLEM	SOLUTION
Main valve will not open	
<ul style="list-style-type: none"> Water cannot exhaust from top of piston 	Check status of manual valves and electrical connection to solenoids (if any) in external pilot piping
<ul style="list-style-type: none"> Insufficient inlet pressure 	Ensure inlet isolating valve is open and there is at least 5 to 10 PSI inlet pressure present. Small sizes require 10 PSI, minimum decreases with size.
<ul style="list-style-type: none"> Vent tube blocked 	Ensure vent tube (22) is open to atmosphere
<ul style="list-style-type: none"> Indicator rod packing too tight 	Turn indicator gland (17) counterclockwise in quarter turn increments
Main valve will not close	
<ul style="list-style-type: none"> Inlet pressure cannot be applied to top of piston 	Check status of manual valves and electrical connection to solenoids (if any) in external pilot piping
<ul style="list-style-type: none"> Wye-strainer clogged 	Clean strainer
Leakage through main valve when closed	
<ul style="list-style-type: none"> Debris in valve 	Remove debris, inspect for damage
<ul style="list-style-type: none"> Worn or damaged seat ring (10) 	Inspect, replace
Excessive leakage through vent tube (slight or intermittent leakage is normal)	
<ul style="list-style-type: none"> Worn piston cup (4) and/or liner cup (7) 	Replace
<ul style="list-style-type: none"> Vent tube (22) loose or its threaded connection to liner (3) not sealed 	Connection into liner (3) must be leak tight. Tighten and/or apply thread sealant.
Excessive leakage past indicator rod (slight or intermittent leakage is normal)	
<ul style="list-style-type: none"> Indicator packing (18) worn or not sufficiently compressed 	Turn indicator gland (17) clockwise one quarter to one half turn. DO NOT OVERTIGHTEN. If leakage does not stop, replace indicator packing.

REPAIR PROCEDURES

GA Industries differential piston main valves are fully serviceable and repairable while the body remains bolted in the line. No special tools are required for normal repair. Due to the weight of the internal components, servicing large valves requires overhead lifting equipment.

Special care must be utilized when servicing differential piston main valves when installed such that the piston is in a horizontal position. Service can be more easily performed if large valves installed in this manner are first removed from the line.

Repair kits are available (see REPAIR KITS) and should be on hand before starting any repairs.

The valve should be disassembled only to the point necessary to perform the repair.

These repair procedures apply only to the main valve. External pilot piping should be removed prior to undertaking disassembly of the main valve. Adequate unions are provided in the control piping to facilitate removal.

CAUTION

Repairs should be conducted by skilled technicians who have read all instructions and are familiar with the equipment and associated drawings. Follow all safety procedures.

WARNING

Before starting repairs, ensure valve is isolated from the system and properly locked out and tagged to prevent accidental pressurization. Completely depressurize the valve before commencing work.

INSTALLING A 12" to 20" REPAIR KIT

- Remove indicator gland (17) and indicator packing (18)
- Scribe or mark an alignment line on the OD of the cover and the top flange of the valve body to ensure cover is properly aligned during assembly
- Remove cover bolts/nuts (14)
- Remove cover (13) lifting straight up to avoid damaging or bending the indicator rod (16)
- Remove cover gasket (15)
- Loosen indicator rod lock nut (20) and remove indicator rod (16).
- Make a mark across the top of the liner and body to permit alignment when the liner is replaced.
- Remove the vent tube gland (23), vent tube packing (24) and unscrew the vent tube (22)
- Remove piston (2). DO NOT use indicator rod to pull out the piston. If necessary, remove indicator rod bushing (19) and install 5/8-11 eyebolt to lift piston out of the valve (18" & 20" is 1"-14).
- Remove the piston cup follower screws (6), piston cup follower (5) and piston cup (4).
- Remove the seat ring (10) by removing the follower screws (12) and follower (11).
- Remove the liner (3), liner cup follower screws (9), liner cup follower (9) and liner cup (7).
- Using very fine wet or dry emery cloth, sand the large ID of the liner and the small OD of the piston

to shiny metal. Inspect for deep scoring or gouges on those surfaces that cannot be polished out. Consult factory for evaluation if unsure. See next section if new liner is needed.

14. Clean the top of the body (1) and liner (3) and the mating surfaces of the cover (13) of any gasket residue.
15. Install new liner cup (7) ensuring the lips are pointing into the valve. Install the liner cup follower (8) and screws (7) and tighten uniformly in an alternating pattern. Do not tighten so much as to deform the follower. Apply a very light coating of lightweight lubricant such as petroleum jelly.
16. Install assembled liner in valve body and align marks. Apply thread sealant to one end of the vent tube (23), install in threaded hole in liner and tighten. Install vent tube packing (24) by wrapping it around the vent tube and tamping it into the cavity until 2 or 3 internal threads are exposed. Cut off the excess. Install vent tube gland (23) and lightly tighten.
17. Install a new seat ring (10), follower ring (11) and screws (12) and tighten. Do not over-tighten to the point where the seat ring or the follower ring deforms.
 - a. Reducing service pistons: trim any rubber that extrudes beyond the small OD of the piston with a sharp utility type razor knife.
18. Install the new piston cup (4) ensuring the lips are pointed toward the large diameter end of the piston. Install the follower ring (5) and screws (6) and tighten uniformly in an alternating pattern. Do not tighten so much as to deform the follower. Apply a very light coating of lightweight lubricant such as petroleum jelly.
19. Apply a thin coating of lubricant to the large ID of the liner and the small OD of the piston.
20. Run a finger under the liner cup to flare its lip inward to facilitate an initial seal. Install the piston being careful not to damage the cups.
21. Install the indicator rod bushing (19). Clean and polish the indicator rod (16) with very fine emery cloth and install with indicator rod lock nut (20). Tighten lock nut.
22. Place new cover gasket (15) on top of valve aligning bolt holes.
23. Align cover (13) and lower over indicator rod (16) *being careful not to bend the rod*. Install cover bolt/nuts (14) and tighten in alternating pattern.
24. Install new indicator packing (18) by wrapping it around the indicator rod and tamping until 2 or 3 threads are exposed. Cut off excess.
25. Install indicator gland (17) and tighten to compress packing only until resistance is felt. **DO NOT OVERTIGHTEN**. Packing compression can be adjusted once pressure has been introduced.
26. Replace pilot piping, slowly introduce pressure to the valve and check for leaks. Tighten indicator rod gland (17) and vent tube gland (23) only as much as needed to stop leakage.

INSTALLING A NEW LINER

New liners are not drilled and tapped to accept the vent tube. Follow these instructions to ensure the liner is properly aligned before drilling/tapping.

1. Make a mark on the top flange of the new liner centered on the location of one of the two bosses on the side of the liner.
2. Make a mark on the top flange of the body centered on the location of the vent tube
3. Install liner in the valve body ensuring the liner is flush with the top of the valve body and the two marks are aligned.
4. Loosely install the vent tube gland (23) and slide in the vent tube (22). Insert a center punch through the vent tube and punch a mark in the liner.
5. Remove the vent tube (22), gland (23) and liner (3).
6. Tap drill the liner to accept the vent tube:
 - a. 12" and 14" – tap drill 37/64" and tap 3/8" NPT
 - b. 16" to 20" – tap drill 23/32" and tap 1/2" NPT
7. Install liner in body and loosely screw in the vent tube and gland. If everything fits, remove gland, vent tube and liner and proceed with reassembly Step 15 in previous section.

REMOVING & INSTALLING A NEW SEAT CROWN

Note: The seat crown (21) in reducing service valves (see Table 1) is threaded in and bonded and is not easily removed. If damaged, it may have to be "cut out."

Removing a water service seat crown:

1. After the piston and liner have been removed, reach inside the seat crown (21) through the V-ports and pull up while slightly rotating. In the unlikely event the liner cannot be extracted from the valve body in this manner, refer to Figure 5 and follow these steps.
 - a. The "lower bar" is a steel bar approximately 1" x 1/2" x long enough to be inserted through opposite V-ports and engage the liner. It should be drilled and tapped 5/8"-11 at its center.
 - b. The "upper bar" is a steel bar the same size as the lower bar but with a length equal to the OD of the valve's top flange. It should be drilled through 1 1/32" at its center.
 - c. Support the upper bar on wooden blocks positioned just outside the OD of the liner.
 - d. Insert a piece of 5/8"-11 all-thread through the upper bar and thread into the lower bar. It should be long enough to extend 1 to 2 inches beyond the upper bar.
 - e. Install two 5/8"-11 hex nuts on the all thread and turn both nuts clockwise until resistance is felt.
 - f. Continue to slowly turn the nuts to "jack" the liner outward. After a few turns the liner should "pop" at which time it can be removed.

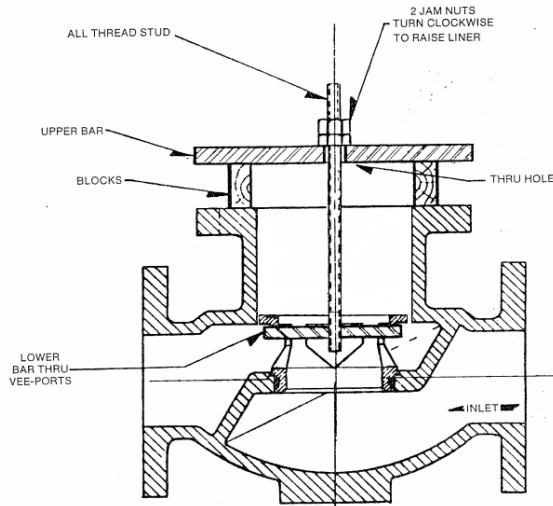

Figure 5

Installing a new water service seat crown:

1. Lubricate and install a new seat crown O-ring (35) in seat crown (21)
2. Clean the surface in the body where the seat crown (21) will sit
3. Lubricate the inside of the bore in the body where the seat crown is inserted
4. Carefully lower the seat crown (21) with O-ring (35) through the top of the body (large valves will require overhead lifting equipment) until it is inserted into the body bore being careful not
5. Ensure it is fully inserted and seated before continuing with reassembly step 14 on page 4.

REPLACEMENT PARTS

Genuine replacement parts are available from your local GA Industries representative or from the factory:

VAG USA, LLC
 234 Clay Avenue
 Mars, PA 16046 USA
 Telephone: 724-776-1020
 Fax: 724-776-1254
 E-mail: quotes-ga@vag-group.com

Please have the nameplate data available when ordering parts.

REPAIR KITS

The below Soft Goods Repair Kits are applicable to 12" to 20" GA Industries differential piston main valves. Prior to 2014 the first two digits of the SO number are the year (660217 = 1966, 800907, 80 = 1980, 020100, 02 = 2002), followed by a sequential number. Beginning in 2014 the SO numbers start with 432 (43203718) followed by a sequential number and do not indicate the year.

The water service kits contain part numbers 4, 7, 10, 15, 18, 24 and 35. Part number 35 is not included in the reducing service kits.

Water Service Kits

Size	Kit Number	Part Number
12"	WS12	2-80-23000-008
14"	WS14	2-80-23000-008
16"	WS16	2-80-23000-010
18" & 20"	WS18/20	2-80-23000-014

Reducing Service Kits

Size	Kit Number	Part Number
12"	R12	2-80-23000-007
14"	R14	2-80-23000-007
16"	R16	2-80-23000-009
18" & 20"	R18/20	2-80-23000-012

All other parts are ordered separately.

Consult factory for valves with older serial numbers.

PARTS LIST

Refer to Figures 6, 7, 8 and 9 for parts location.

Item	Part Name
1	Body
2	Piston
2a	Baffle
3	Liner
4	Piston Cup
5	Piston Cup Follower
6	Piston Cup Follower Screw
7	Liner Cup
8	Liner Cup Follower
9	Liner Cup Follower Screw
10	Seat Ring
11	Seat Ring Follower
12	Seat Ring Follower Screws
13	Cover
14	Cover Bolts/Nuts
15	Cover Gasket
16	Indicator Rod
17	Indicator Gland
18	Indicator Packing
19	Indicator Bushing
20	Indicator Lock Nut
21	Seat Crown
22	Vent Tube
23	Vent Tube Gland
24	Vent Packing
35	Seat Crown O-Ring

WARRANTY:

The Warranty for GA Industries valves is included in our Terms and Conditions which can be found here: <https://gaindustries.com/terms>

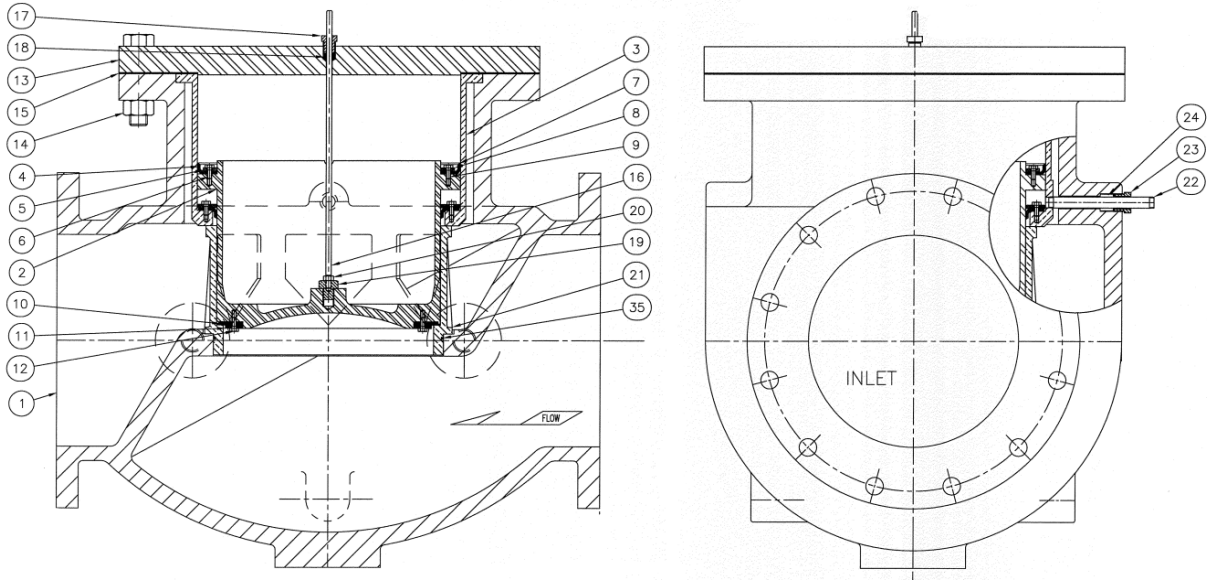

Figure 6 Globe Body, Reducing Service

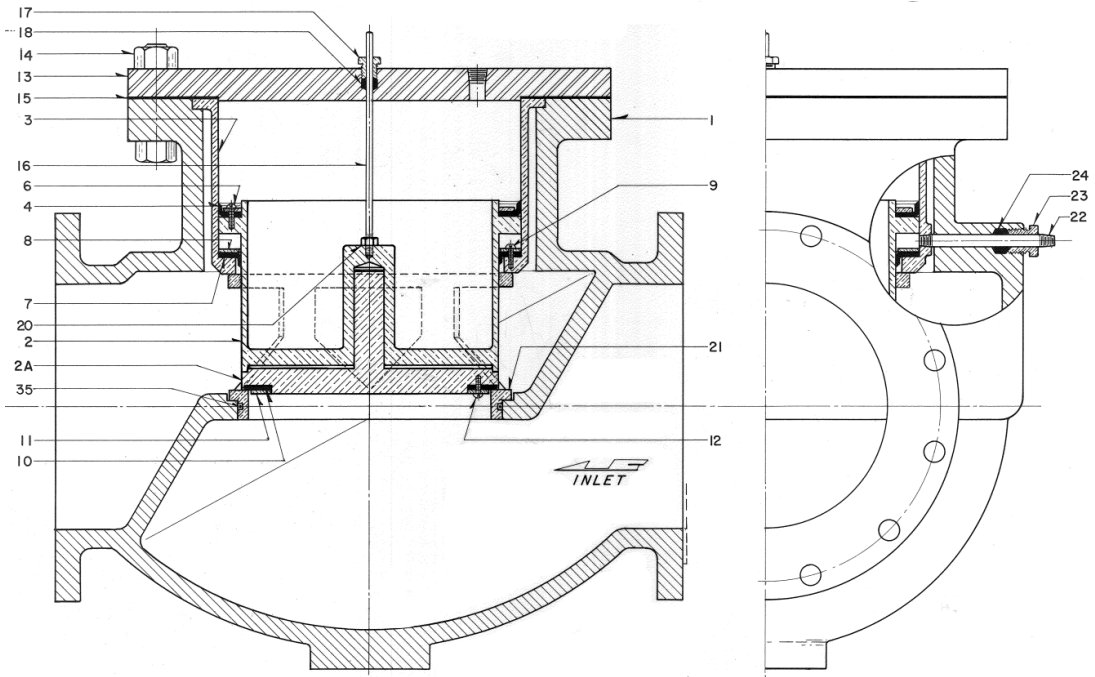

Figure 7 Globe Body Stop Check Piston, Water Service

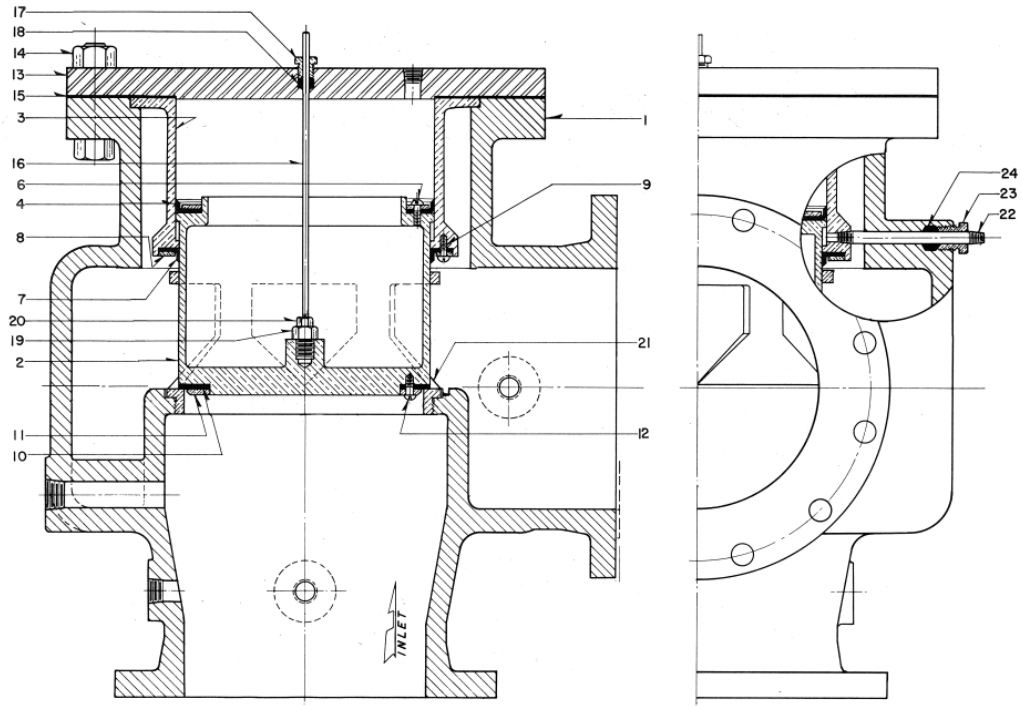

Figure 8 Angle Body, Reducing Service

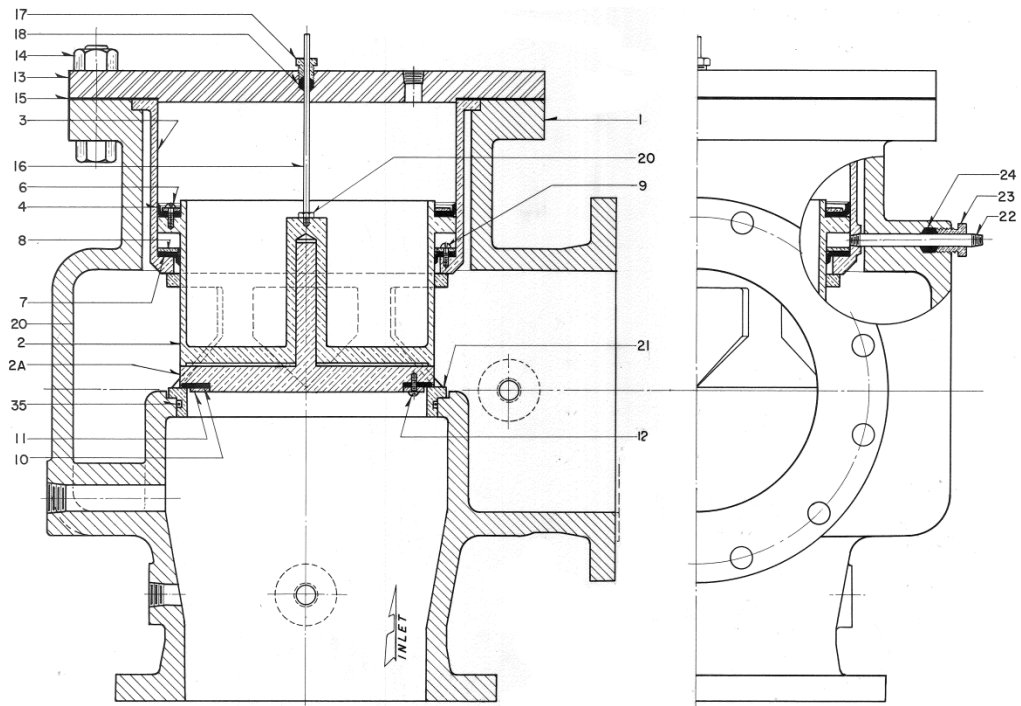

Figure 9 Angle Body, Stop Check, Water Service

Section 4

OPERATION AND MAINTENANCE MANUAL

1/2" and 1" Figure 43 Reducing Pilots Drawings D-1020, D-1062 and D-1025

TABLE OF CONTENTS

Introduction	1
Description of Operation	1
Valve Construction	1
Start-Up	1
Preventive Maintenance	1
Adjusting the Pressure Setting	2
Trouble Shooting	2
Repair Procedures	2 & 3
Replacement Parts	3
Repair Kits	3
Warranty	4
1/2" Pilot Drawing/Parts Location.....	4
1" Pilot Drawing/Parts Location	4



234 Clay Avenue • Mars, PA 16046 USA
Telephone (724) 776-1020 • Fax (724) 776-1254
E-mail: info-ga@vag-group.com

Manual Number IOM-43P-092721



WARNING: Cancer and Reproductive Harm – www.Prop65Warnings.ca.gov

INTRODUCTION

This manual provides information about the operation and proper maintenance of standard GA Industries Figure 43 pressure reducing pilots used the pilot on many GA Industries differential piston actuated, pilot-operated pressure reducing valves. The pilot valve is ruggedly constructed to provide many decades of dependable service with minimal maintenance.

CAUTION

The valve is NOT recommended for use with toxic, corrosive, or flammable fluids.

The Shop Order (SO) Number, Figure Number, size, and pressure rating are stamped on a nameplate attached to the main valve. Please refer to the SO number when ordering parts.

DESCRIPTION OF OPERATION

The Figure 43 pilot is a direct acting, spring loaded, diaphragm actuated pressure reducing valve. In the absence of pressure, the valve is pushed open by the compression spring. Downstream system pressure is applied to the underside of the diaphragm through a separate "impulse line" producing a closing force. Water will flow through the open valve but as the downstream pressure increases it compresses the spring and lifts the disc toward the seat. The amount of spring compression determines the downstream (reduced) pressure setting.

The Figure 43 is "pressure balanced" such that changes in inlet pressure have no effect on the reduced pressure.

When incorporated into a differential piston control valve's pilot system, the Figure 43 pilot controls the pressure applied to the top of the main valve piston. Its action determines whether the main valve is closed or open.

As demand varies, the pilot regulates the pressure applied to the top of the piston to maintain the desired downstream pressure within a narrow deadband. Should demand become zero, the pilot will close thereby closing the main valve.

VALVE CONSTRUCTION

The standard valve body is made from lead free bronze. Internal "wetted" components are made from stainless steel and the valve seat is made from Buna-N rubber.

The diaphragm is nylon reinforced Buna-N. The adjusting spring is alloy steel and is enclosed in a standard aluminum spring chamber.

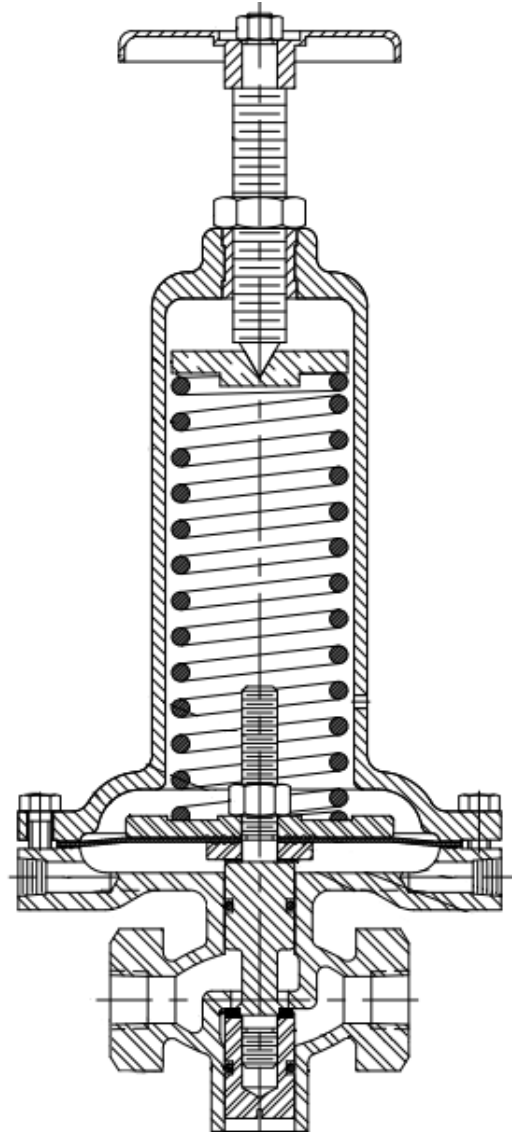

1/2" Figure 43 Shown

Refer to Page 4 for parts identification and location for each size Figure 43 pilot valve.

START-UP

Refer to the Installation, Operation and Maintenance Manual for the start-up procedure applicable to the pilot-operated pressure reducing valve being installed.

PREVENTATIVE MAINTENANCE

The Figure 43 pilot valve does not require routine lubrication or adjustments. After the initial start-up, periodic visual inspection is recommended.

Perform any additional preventative maintenance procedures as recommended in the Installation, Operation and Maintenance Manual for the pilot-operated control valve being installed

ADJUSTING THE PRESSURE SETTING

The Figure 43 pilot valve's reduced pressure setting is typically factory set but can be field adjusted within the range of the pilot's installed spring.

If the required pressure setting is higher than the installed spring's maximum setting, the spring must be changed.

Turning the pilot handwheel clockwise raises the reduced pressure, turning it counterclockwise lowers the reduced pressure. The below tables list the change in pressure per full 360 degree turn of the handwheel.

GA Industries Figure 43 pilot valves are available with ½" or 1" NPT connections. The ½" size can be supplied with a 5-inch or 7-inch diaphragm, as measured by the outside diameter of the pilot. The 1" is supplied only with a 7-inch diaphragm.

½" Pilot with 5-inch Diaphragm

SPRING COLOR	MAX REDUCED PRESSURE SETTING	WIRE DIAMETER	CHANGE PER FULL TURN
White	20 PSI	0.250"	0.64 PSI
Green	45 PSI	0.313"	1.7 PSI
Black	110 PSI	0.375"	4.5 PSI
Red	155 PSI	0.438"	9.1 PSI
Yellow	250 PSI	0.500"	18.6 PSI
Blue	330 PSI	0.563"	36.0 PSI

½" Pilot with 7-inch Diaphragm

SPRING COLOR	MAX REDUCED PRESSURE SETTING	WIRE DIAMETER	CHANGE PER FULL TURN
Yellow	10 PSI	0.219"	0.25 PSI
Green	20 PSI	0.250"	0.50 PSI
Black	30 PSI	0.313"	1.2 PSI
White	50 PSI	0.375"	2.3 PSI
Red	100 PSI	0.500"	7.2 PSI
Blue	125 PSI	0.563"	11.0 PSI

1" Pilot with 7" Diaphragm

SPRING COLOR	MAX REDUCED PRESSURE SETTING	WIRE DIAMETER	CHANGE PER FULL TURN
Yellow	10 PSI	0.219"	0.50 PSI
Green	20 PSI	0.250"	0.55 PSI
Black	35 PSI	0.313"	1.3 PSI
White	55 PSI	0.375"	2.5 PSI
Red	110 PSI	0.500"	8.0 PSI
Blue	135 PSI	0.563"	12.0 PSI

TROUBLESHOOTING

Leakage from the bottom of the valve

- Worn lower stem O-ring (3) – Replace

Leakage from weep hole in spring chamber (14)

- Loose stem nut (11) - Tighten
- Worn/damaged diaphragm (9) – Replace

Leakage detected from main valve outlet that stops when pilot discharge stop valve is closed

- Worn/damaged pilot rubber seat (2) – Replace
- Damaged valve body seat (1) – Replace pilot

Refer to page 4 for part location. Rubber parts are included in Repair Kit, see page 3.

REPAIR PROCEDURE

Most repairs involve the installation of a soft goods repair kit. It's a rare case when any of the metal components need replacement but they should be inspected for wear or damage upon disassembly and replaced if needed.

CAUTION

Repairs should be conducted by skilled technicians who have read all instructions and are familiar with the equipment and associated drawings. Follow all safety procedures.

WARNING

Before starting repairs, ensure valve is isolated from the system and properly locked out and tagged to prevent accidental pressurization. Completely depressurize the valve before commencing work.

The pilot valve can be repaired without removing it from the control valve piping. Ensure all stop valves in control piping that could supply pressure to the pilot being repaired are closed.

Disassembly:

1. Note the position of the handwheel (18) by exactly measuring its distance from the adjusting screw locknut (17) or counting the number of exposed threads on the adjusting screw (16). This will allow the pilot to be returned to its original pressure setting after repair.
2. Loosen the adjusting screw locknut (17) and turn the handwheel (18) counterclockwise to relieve all spring compression. It's not necessary to completely unscrew the adjusting screw (16) from the spring chamber (14).
3. Remove the spring chamber screws (15) and lift off the spring chamber (14) exposing the spring guide (13) and spring (12). Inspect the spring for excessive corrosion, replace if necessary. Remove the spring guide and spring and set aside.
4. Remove the body cap (22) and O-ring (22A) on the bottom of 1" pilots.

5. ½" and 1" pilots have a screwdriver slot in the bottom of the lower stem (4). With a screwdriver securing the lower stem, turn the stem nut (11) counterclockwise with another wrench. Remove the stem nut (11), diaphragm disc (10) and diaphragm (9).
6. For ½" pilots, remove the diaphragm washer (5) and stem gasket (8).
7. With the screwdriver securing the lower stem, use a wrench to grasp the upper stem (6) by its wrench flats and unscrew the lower stem/spool (4) from the upper stem (6).
8. Internal components can now be removed through the top and bottom of the body by hand.
9. Remove the upper and lower stem/spool O-rings (3 & 7) and the rubber seat (2).
10. Inspect the sealing surfaces of the internal components, body, and bottom cap for wear, scoring or gouges. Pay particular attention to the surface where the rubber seat (2) seals on the body for evidence of wear or damage. Clean and polish all sealing surfaces using very fine wet or dry emery cloth. Replace any components that cannot be returned to an unblemished sealing surface.

Reassembly:

1. Apply a thin coat of approved grease to the new upper and lower O-rings (3 & 7) and install in the grooves on the upper (6) and lower stem (4).
2. Install a new rubber seat (2) in the recess on the bottom of the lower stem/spool (4).
3. Apply a thin coat of grease to the inside of the body bore and insert the upper stem into the body being careful not to damage the upper stem O-ring (7). Push in by hand until the rubber seat (2) is resting on the body seat.
4. For ½" pilots:
 - a. Apply a thin coat of approved grease inside the bottom bore of the body.
 - b. Insert the lower stem (4) through the bottom of the body being careful not to damage the lower stem O-ring (3).
5. For 1" pilots, insert the lower stem (4) through the bottom of the body.
6. Using a wrench and a screwdriver, tightly screw the lower stem and upper stems together.
7. For 1" pilots:
 - a. Apply a thin coat of approved grease to the inside of the body cap (22).
 - b. Apply approved grease to the new bottom cap O-ring (22A) and insert into the groove on the bottom of the body.
 - c. Install the body cap (22) being careful not to damage the lower stem/spool O-ring (3). Tighten securely.
8. Install the stem nut (11) a few turns and use it to pull up and push down to ensure the internal components move without binding or sticking. Remove the stem nut.
9. For ½" pilots, install a new stem gasket (8) and the diaphragm washer (5).

10. Place the diaphragm (9) over the stem followed by the diaphragm disc (10) and stem nut (11).
11. Using two wrenches, secure the upper stem (6) while tightening the stem nut (11).
12. Place the spring (12) in the recessed groove in the diaphragm disc (10) and the spring guide on top of the spring (12).
13. Place the spring chamber (14) over the spring, being careful not to move the spring or knock off the spring guide.
14. Align the holes in the spring chamber (14) with those in the body (1) and ensure the diaphragm (9) will be clamped all around.
15. Install spring chamber screws and snug then tighten in an alternating pattern. These screws need to be very tight.
16. Turn the handwheel (16) clockwise until resistance is felt.
17. Continue to turn the handwheel until it is returned to its original position.
18. If it had been removed, the pilot can now be re-installed in the control valve pilot piping.
19. Slowly open isolating and/or stop valves to introduce pressure. Bleed air from the pilot by loosening the pipe plug opposite from where the impulse line is connected to the pilot. Tighten after the air has been purged.
20. The control valve can now be put back into service.

REPLACEMENT PARTS

Genuine replacement parts are available from your local GA Industries representative or from the factory:

VAG USA, LLC
 234 Clay Avenue
 Mars, PA 16046 USA
 Telephone: 724-776-1020
 Fax: 724-776-1254
 E-mail: quotes-ga@vag-group.com

Please have the nameplate data available when ordering parts.

REPAIR KITS

The below Soft Goods Repair Kits are applicable to GA Industries Figure 43 reducing pilots. The ½" pilot repair kits contain item numbers 2, 3, 7, 8 and 9. The 1" pilot repair kits contain items 2, 3, 7, 9 and 22A.

Reducing Pilot Repair Kits

Size	Kit Number	Part Number
½" -5 inch	P5	2-80-23000-026
½" -7 inch	P7	2-80-23000-027
1"	P1REL/RED	2-80-23000-017

All other parts are ordered separately.

WARRANTY:

The Warranty for GA Industries valves is included in our Terms and Conditions which can be found here: <https://gaindustries.com/terms>

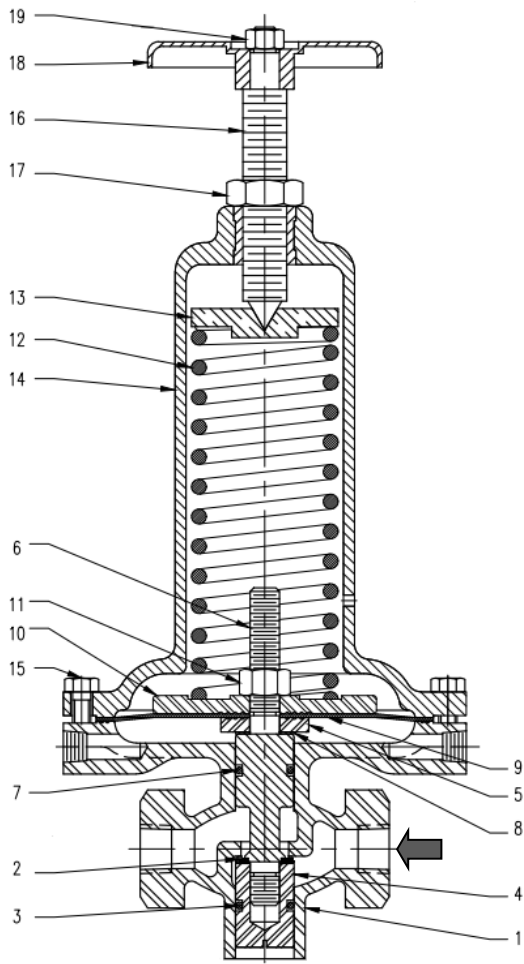

1/2" Pilot

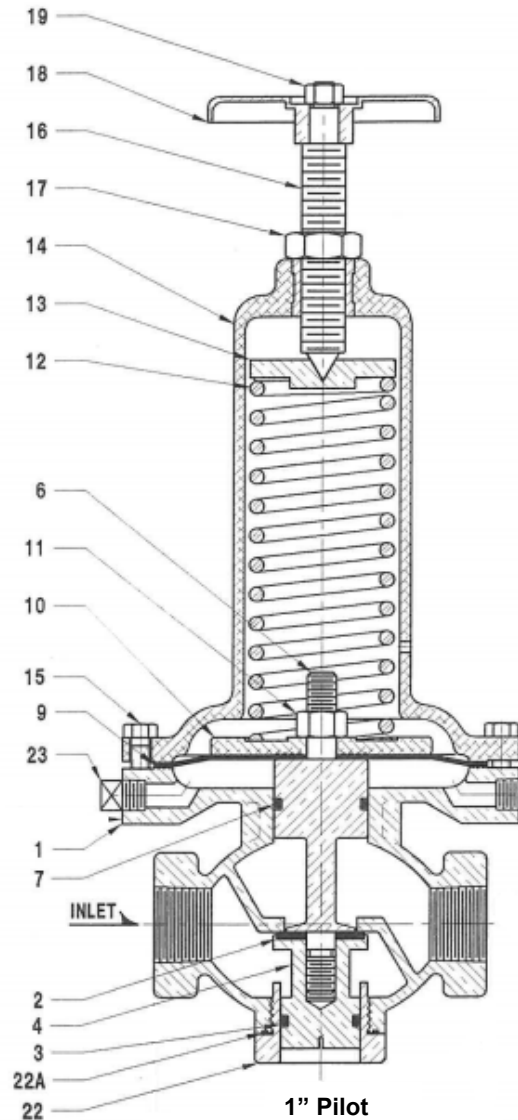

1" Pilot

REDUCING PILOT PARTS LIST

Item	Description	Item	Description
1	Body	11	Stem Nut
2	Rubber Seat	12	Spring
3	Lower Stem O-Ring	13	Spring Guide
4	Lower Stem	14	Spring Chamber
5	Diaphragm Washer	15	Spring Chamber Screw
6	Upper Stem	16	Adjusting Screw
7	Upper Stem O-Ring	17	Adjusting Screw Lock Nut
8	Stem Gasket	22	Body Cap
9	Diaphragm	22A	Body Cap O-ring
10	Diaphragm Disc		

Section 5

OPERATION AND MAINTENANCE MANUAL

1/2", 1" and 2" Figure 667 Relief Pilots

Drawings B-1030, B-1040, B-1076 and B-1078

TABLE OF CONTENTS

Introduction	1
Description of Operation	1
Valve Construction	2
Start-Up	2
Preventive Maintenance	2
Adjusting The Pressure Setting	2
Trouble Shooting	2
Repair Procedures	2 & 3
Replacement Parts	4
Repair Kits	4
Warranty	4
1/2" Pilot Drawing/Parts Location.....	4
1" Pilot Drawing/Parts Location	5
2" Pilot Drawing/Parts Location	5



234 Clay Avenue • Mars, PA 16046 USA
Telephone (724) 776-1020 • Fax (724) 776-1254
E-mail: info-ga@vag-group.com

Manual Number IOM-667P-041621



WARNING: Cancer and Reproductive Harm – www.Prop65Warnings.ca.gov

OPERATION and MAINTENANCE

1/2", 1" and 2" Relief Pilots

INTRODUCTION

This manual provides information about the operation and proper maintenance of standard GA Industries Figure 667 relief pilots. The relief pilot is an integral part of all GA Industries differential piston actuated, pilot-operated surge relief and pressure sustaining valves. The pilot valve is ruggedly constructed to provide many decades of dependable service with minimal maintenance.

CAUTION

The valve is NOT recommended for use with toxic, corrosive, or flammable fluids.

The Shop Order (SO) Number, Figure Number, size and pressure rating are stamped on a nameplate attached to the valve. Please refer to the SO number when ordering parts.

DESCRIPTION OF OPERATION

The pressure relief pilot controls the pressure applied to the top of the main valve piston. Its action determines whether the main valve is closed or open.

The Figure 667 pilot is a direct acting, spring loaded, pressure balanced, diaphragm actuated valve. The valve is held closed by the force produced by the compression spring. System pressure is applied to the underside of the diaphragm through an "impulse line" producing an opening force. The pilot valve opens when the opening force exceeds the closing force. The amount of spring compression determines the "set pressure" at which the valve opens.

The Figure 667 pilot is "pressure balanced" such that changes in inlet pressure have no effect on the pressure at which it opens.

The valve is typically incorporated into a differential piston control valve pilot system. The pilot is closed whenever system pressure is below its set pressure and it retains pressure on top of the main valve piston thereby holding the main valve closed. The pilot opens when system pressure rises above the set pressure and relieves pressure from on top the main valve piston allowing the main valve to open.

VALVE CONSTRUCTION

The valve body is made from lead free bronze. Internal "wetted" components are made from stainless steel and the valve seat is made from Buna-N rubber.

The diaphragm is nylon reinforced Buna-N. The adjusting spring is alloy steel and is enclosed in an aluminum spring chamber.

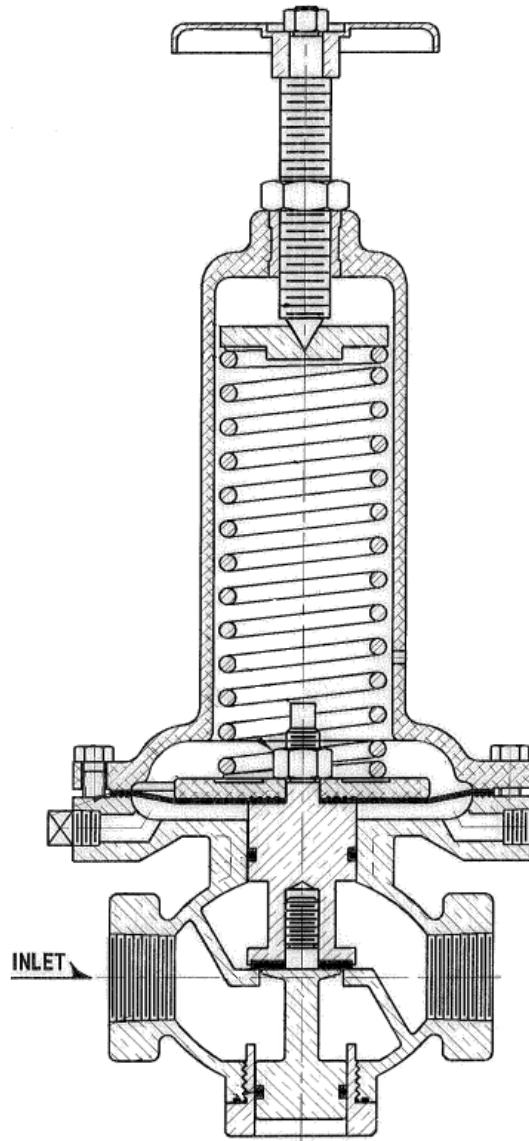

Refer to Pages 4 and 5 for parts identification and location for each size Figure 667 pilot valve.

START-UP

Refer to the Installation, Operation and Maintenance Manual for the start-up procedure applicable to the pilot-operated control valve being installed.

PREVENTATIVE MAINTENANCE

The Figure 667 pilot valve does not require routine lubrication or adjustments. After the initial start-up, periodic visual inspection is recommended.

Perform any additional preventative maintenance procedures as recommended in the Installation, Operation and Maintenance Manual for the pilot-operated control valve being installed

ADJUSTING THE PRESSURE SETTING

The pressure at which the Figure 667 pilot valve opens is typically factory set but can be field adjusted within the range of the pilot's installed spring.

If the required pressure setting is higher than the installed spring's maximum setting, the spring must be changed.

Turning the pilot handwheel clockwise raises the opening pressure, turning it counterclockwise lowers the opening pressure. The below tables list the change in pressure per full 360 degree turn of the handwheel.

GA Industries Figure 667 pilot valves are available with 1/2", 1" or 2" NPT connections. The 1/2" size can be supplied with a 5-inch or 7-inch diaphragm, as measured by the outside diameter of the pilot. The 1" and 2" sizes are supplied only with a 7-inch diaphragm.

1/2" Size with 5-inch Diaphragm

SPRING COLOR	MAX SETTING	WIRE DIAMETER	CHANGE PER FULL TURN
White	20 PSI	0.250"	0.64 PSI
Green	45 PSI	0.313"	1.7 PSI
Black	110 PSI	0.375"	4.5 PSI
Red	155 PSI	0.438"	9.1 PSI
Yellow	250 PSI	0.500"	18.6 PSI
Blue	330 PSI	0.563"	36.0 PSI

1/2" Size with 7-inch Diaphragm

SPRING COLOR	MAX SETTING	WIRE DIAMETER	CHANGE PER FULL TURN
Yellow	10 PSI	0.219"	0.25 PSI
Green	20 PSI	0.250"	0.50 PSI
Black	30 PSI	0.313"	1.2 PSI
White	50 PSI	0.375"	2.3 PSI
Red	100 PSI	0.500"	7.2 PSI
Blue	125 PSI	0.563"	11.0 PSI

1" Size with 7" Diaphragm

SPRING COLOR	MAX SETTING	WIRE DIAMETER	CHANGE PER FULL TURN
Yellow	10 PSI	0.219"	0.50 PSI
Green	20 PSI	0.250"	0.55 PSI
Black	35 PSI	0.313"	1.3 PSI
White	55 PSI	0.375"	2.5 PSI
Red	110 PSI	0.500"	8.0 PSI
Blue	125 PSI	0.563"	12.0 PSI

2" Size with 7" Diaphragm

SPRING COLOR	MAX SETTING	WIRE DIAMETER	CHANGE PER FULL TURN
Yellow	12 PSI	0.219"	1.2 PSI
Green	25 PSI	0.250"	0.6 PSI
Black	40 PSI	0.313"	1.4 PSI
White	60 PSI	0.375"	2.8 PSI
Red	125 PSI	0.500"	9.0 PSI
Blue	153 PSI	0.563"	13.0 PSI

TROUBLESHOOTING

Leakage from the bottom of the valve

- Worn lower stem O-ring (3) – Replace

Leakage from weep hole in spring chamber (14)

- Loose stem nut (11) - Tighten
- Worn/damaged diaphragm (9) – Replace

Leakage detected from main valve outlet that stops when pilot discharge stop valve is closed

- Worn/damaged pilot rubber seat (2) – Replace
- Damaged valve body seat (1) – Replace pilot

Refer to pages __ to __ for part location. Rubber parts are included in Repair Kit, see page __.

REPAIR PROCEDURE

Most repairs involve the installation of a soft goods repair kit. It's a rare case when any of the metal components need replacement but they should be inspected for wear or damage upon disassembly and replaced if needed.

CAUTION

Repairs should be conducted by skilled technicians who have read all instructions and are familiar with the equipment and associated drawings. Follow all safety procedures.

WARNING

Before starting repairs, ensure valve is isolated from the system and properly locked out and tagged to prevent accidental pressurization. Completely depressurize the valve before commencing work.

The pilot valve can be repaired without removing it from the control valve piping. Ensure all stop valves in control piping that could supply pressure to the pilot being repaired are closed.

Disassembly:

1. Note the position of the handwheel (18) by exactly measuring its distance from the adjusting screw locknut (17) or counting the number of exposed threads on the adjusting screw (16). This will allow the pilot to be returned to its original pressure setting after repair.
2. Loosen the adjusting screw locknut (17) and turn the handwheel (18) counterclockwise to relieve all spring compression. It's not necessary to completely unscrew the adjusting screw (16) from the spring chamber (14).
3. Remove the spring chamber screws (15) and lift off the spring chamber (14) exposing the spring guide (13) and spring (12). Inspect the spring for excessive corrosion, replace if necessary. Remove the spring guide and spring and set aside.
4. Remove the body cap (8) and O-ring (23) on the bottom of 1" and 2" pilots.
5. ½" and 1" pilots have a screwdriver slot in the bottom of the lower stem (4) while the 2" pilot has wrench flats in the lower spool (4). With a screwdriver or wrench securing the lower stem/spool, turn the stem nut (11) counterclockwise with another wrench. Remove the stem nut (11), diaphragm disc (10) and diaphragm (9).
6. For ½" pilots, remove the diaphragm washer (8) and stem gasket (5).
7. With the screwdriver or wrench securing the lower stem/spool, use a wrench to grasp the stem (6) by its wrench flats and unscrew the lower stem/spool (4) from the stem (6).
 - a. Note that 2" pilots have a separate upper spool (5) and stem (6).
8. Internal components can now be removed through the top and bottom of the body by hand.
9. Remove the upper and lower stem/spool O-rings (3 & 7) and the rubber seat (2).
10. Inspect the sealing surfaces of the internal components, body, and bottom cap for wear, scoring or gouges. Pay particular attention to the surface where the rubber seat (10) seals on the body for evidence of wear or damage. Clean and polish all sealing surfaces using very fine wet or dry emery cloth. Replace any components that cannot be returned to an unblemished sealing surface.

Reassembly:

1. Apply a thin coat of approved grease to the new upper and lower O-rings (3 & 7) and install in the grooves on the upper stem/spool and lower stem/spool (4, 5, 6).
2. Install a new rubber seat (10) in the recess on the bottom of the upper stem/spool (6, 5).
3. Apply a thin coat of grease to the inside of the body bore and insert the upper stem (or 2" upper spool and stem) into the body being careful not to damage the upper O-ring. Push in by hand until the rubber seat (10) is resting on the body seat.

4. For ½" pilots only:
 - a. Apply a thin coat of approved grease inside the bottom bore of the body.
 - b. Insert the lower stem (4) through the bottom of the body being careful not to damage the lower stem O-ring (3).
5. For 1" and 2" pilots only, insert the lower stem/spool (4) through the bottom of the body.
6. Using a wrench and a screwdriver (½" and 1" pilots) or two wrenches (2" pilot) tightly screw the lower stem/spool and upper stem together.
7. For 1" and 2" pilots:
 - a. Apply a thin coat of approved grease to the inside of the body cap (22).
 - b. Apply approved grease to the new bottom cap O-ring (23) and insert into the groove on the bottom of the body.
 - c. Install the body cap (22) being careful not to damage the lower stem/spool O-ring (3). Tighten securely.
8. Install the stem nut (11) a few turns and use it to pull up and push down to ensure the internal components move without binding or sticking. Remove the stem nut.
9. For ½" pilots, install a new stem gasket (8) and the diaphragm washer (5).
10. Place the diaphragm (9) over the stem followed by the diaphragm disc (10) and stem nut (11).
11. Using two wrenches, secure the upper stem (6) while tightening the stem nut (11).
12. Place the spring (12) in the recessed groove in the diaphragm disc (10) and the spring guide on top of the spring (12).
13. Place the spring chamber (14) over the spring, being careful not to move the spring or knock off the spring guide.
14. Align the holes in the spring chamber (14) with those in the body (1) and ensure the diaphragm (9) will be clamped all around.
15. Install spring chamber screws and snug then tighten in an alternating pattern. These screws need to be very tight.
16. Turn the handwheel (16) clockwise until resistance is felt.
17. Continue to turn the handwheel until it is returned to its original position.
18. If it had been removed, the pilot can now be re-installed in the control valve pilot piping.
19. Slowly open isolating and/or stop valves to introduce pressure. Bleed air from the pilot by loosening the pipe plug opposite from where the impulse line is connected to the pilot. Tighten after the air has been purged.
20. The control valve can now be put back into service.

REPLACEMENT PARTS

Genuine replacement parts are available from your local GA Industries representative or from the factory:

VAG USA, LLC
 234 Clay Avenue
 Mars, PA 16046 USA
 Telephone: 724-776-1020
 Fax: 724-776-1254
 E-mail: quotes-ga@vag-group.com

Please have the nameplate data available when ordering parts.

REPAIR KITS

The below Soft Goods Repair Kits are applicable to GA Industries Figure 667 relief pilots. The 1/2" pilot repair kits contain item numbers 2, 3, 7, 8 and 9. The 1" and 2" pilot repair kits contain items 2, 3, 7, 9 and 23.

Relief Pilot Repair Kits

Size	Kit Number	Part Number
1/2" -5 inch	P5	2-80-23000-026
1/2" -7 inch	P7	2-80-23000-027
1"	P1REL/RED	2-80-23000-017
2"	P2REL	2-80-23000-023

All other parts are ordered separately.

WARRANTY:

The Warranty for GA Industries valves is included in our Terms and Conditions which can be found here: <https://gairindustries.com/terms>

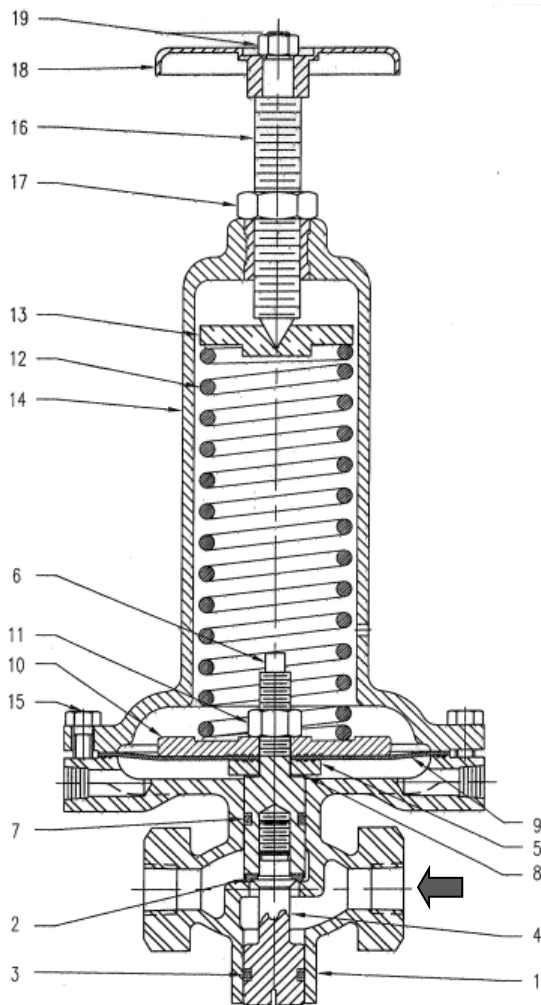

1/2" PILOT PARTS LIST

Item	Description
1	Body
2	Rubber Seat
3	Lower Stem O-Ring
4	Lower Stem
5	Diaphragm Washer
6	Upper Stem
7	Upper Stem O-Ring
8	Stem Gasket
9	Diaphragm
10	Diaphragm Disc
11	Stem Nut
12	Spring
13	Spring Guide
14	Spring Chamber
15	Spring Chamber Screw
16	Adjusting Screw
17	Adjusting Screw Locknut
18	Handwheel
19	Handwheel Nut

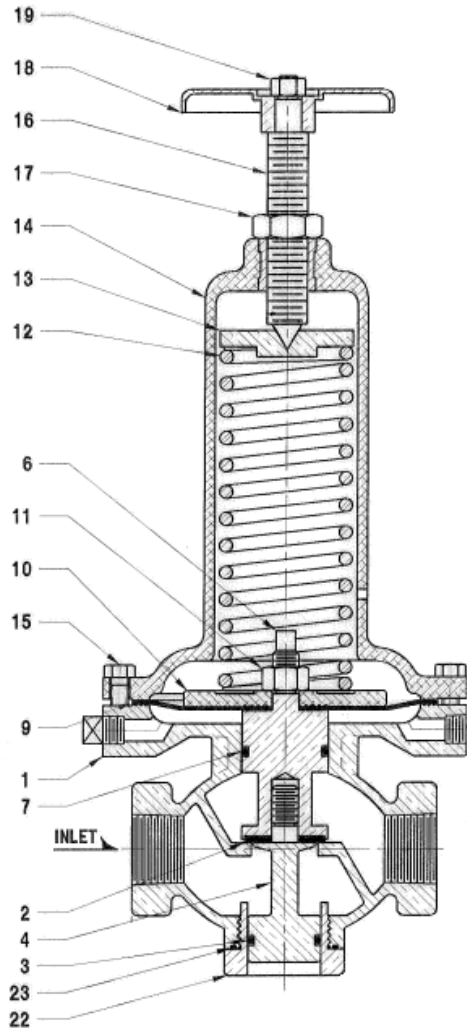

1" PILOT PARTS LIST

Item	Description
1	Body
2	Rubber Seat
3	Lower Stem O-Ring
4	Lower Stem
5	Not Used
6	Upper Stem
7	Upper Stem O-Ring
8	Not Used
9	Diaphragm
10	Diaphragm Disc
11	Stem Nut
12	Spring
13	Spring Guide
14	Spring Chamber
15	Spring Chamber Screws
16	Adjusting Screw
17	Adjusting Screw Locknut
18	Handwheel
19	Handwheel Nut
22	Body Cap Bushing
23	Body Cap Bushing O-Ring

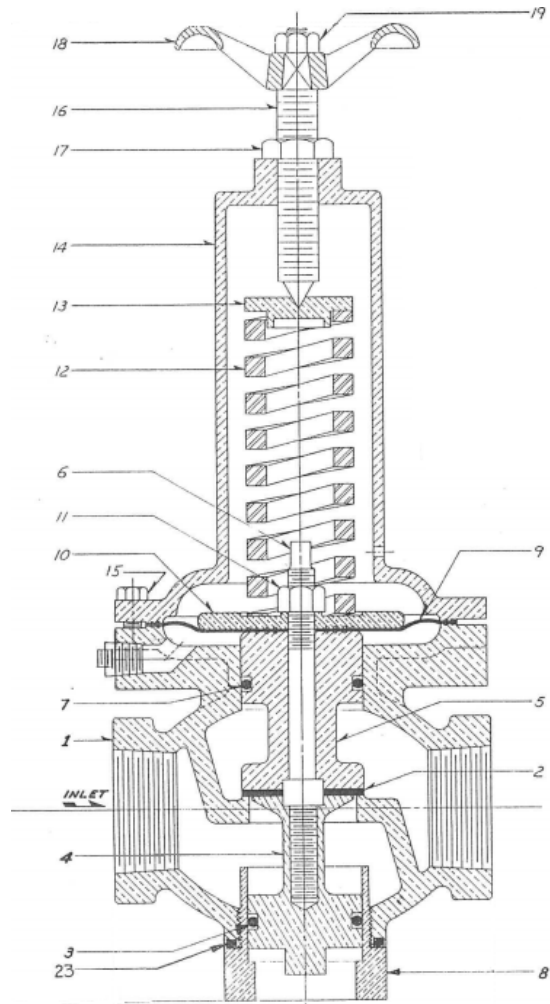

2" PILOT PARTS LIST

Item	Description
1	Body
2	Rubber Seat
3	Lower O-Ring
4	Lower Spool
5	Not Used
6	Upper Spool
7	Upper O-Ring
8	Body Cap
9	Diaphragm
10	Diaphragm Disc
11	Stem Nut
12	Spring
13	Spring Guide
14	Spring Chamber
15	Spring Chamber Screws
16	Adjusting Screw
17	Adjusting Screw Locknut
18	Handwheel
19	Handwheel Nut
22	Body Cap Bushing
23	Body Cap Bushing O-Ring