

SIZE	A	B	C	D	F	G	H	J	WGT
24"	42	19.7	25.4	24	N/A	N/A	1%	20	2,010
30"	51	22.7	29.5	24	1¼-7UNC	8	1%	20	3,875
36"	60	26.6	34.3	28	1½-6UNC	8	1%	24	6,130
42"	72	30.7	39.9	32	1½-6UNC	4	1%	32	9,815
48"	84	37.4	50.0	36	1½-6UNC	4	1%	40	15,865
54"	95	42.3	54.7	32	1¼-5UNC	4	2	40	23,370

PRESSURE DATA, PER AWWA C517		
DESIGN PRESSURE RATING		150 PSI
TEST PRESSURE	SHELL TEST	225 PSI
	SEAT TEST (DIRECT)	150 PSI
	SEAT TEST (REVERSE)	100 PSI

ITEM	NAME	STANDARD MATERIAL
1	BODY	DUCTILE IRON
2	PLUG	DUCTILE IRON/BUNA-N
3	COVER	DUCTILE IRON
4	COVER BOLTS	316 STAINLESS STEEL
5	O-RING	BUNA-N
6	ADAPTER	DUCTILE IRON
7	UPPER THRUST WASHER	ALUMINUM BRONZE
8	UPPER GRIT EXCLUDER	BUNA-N
9	UPPER SHAFT BEARING	316 STAINLESS STEEL
10	V-PACKING	BUNA-N
11	GLAND	DUCTILE IRON
12	GLAND FASTENERS	316 STAINLESS STEEL
13	BOTTOM COVER	DUCTILE IRON
14	BOTTOM COVER O-RING	BUNA-N
15	BOTTOM COVER BOLTS	316 STAINLESS STEEL
16	LOWER SHAFT BEARING	316 STAINLESS STEEL
17	LOWER GRIT EXCLUDER	BUNA-N
18	LOWER THRUST WASHER	ALUMINUM BRONZE
19	PIPE PLUG	304 STAINLESS STEEL

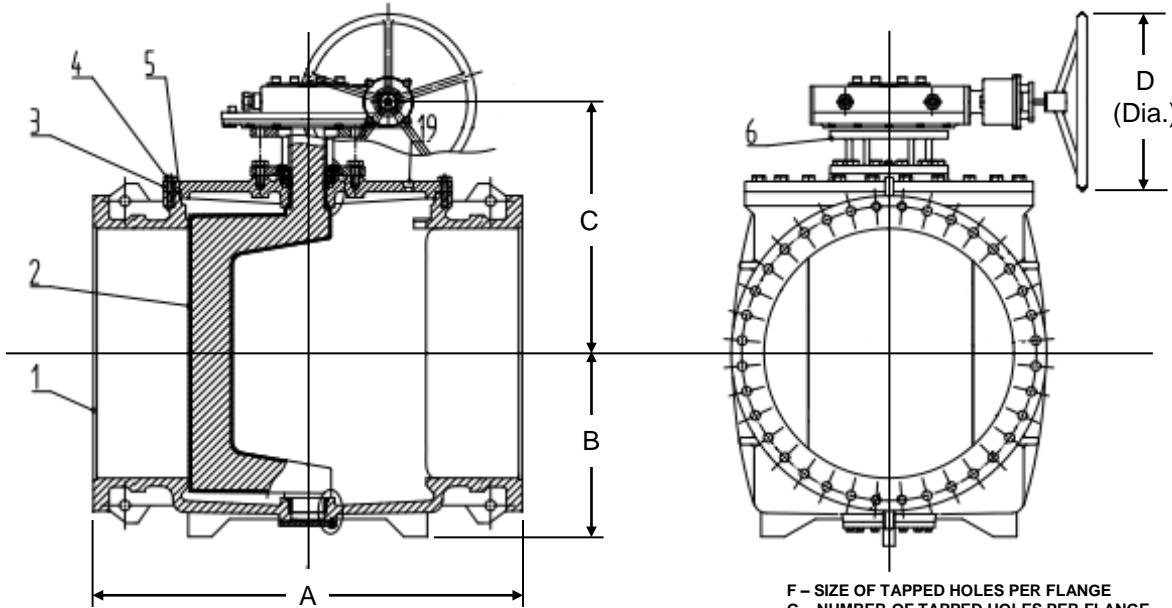

F - SIZE OF TAPPED HOLES PER FLANGE
 G - NUMBER OF TAPPED HOLES PER FLANGE
 H - SIZE OF BOLT HOLES PER FLANGE
 J - NUMBER OF BOLT HOLES PER FLANGE

NOTES

- DESIGN STANDARD AWWA C517
- FLANGE DRILLING PER ANSI B16.1 CLASS 125
- DIMENSIONS AND WEIGHT ARE FOR STANDARD WORM GEAR ACTUATOR WITH HANDWHEEL
- DIMENSIONS IN INCHES, WEIGHT IN POUNDS AND ARE APPROXIMATE. REQUEST CERTIFIED DRAWINGS IF CRITICAL.

UPGRADED FASTENERS TO 316 STAINLESS STEEL	6-18-24	WJN
DESCRIPTION	DATE	BY

GA INDUSTRIES, a VAG Group Brand				
STANDARD PORT FLANGED ECCENTRIC PLUG VALVE WITH WORM GEAR AND HANDWHEEL				
STANDARD TOLERANCES (UNLESS OTHERWISE NOTED) FINISHED SURFACES ONLY X = ±0.02" .XX = ±0.01" .XXX = ±0.002" FRACTIONS ±1/164" ANGLES ±1°	SERIAL NO.	SCALE NONE	DRAWN BY WJN APPR. BY	
	REFERENCES	EFFECTIVE DATE 1-1-2024 TO	FIG. NUMBER B517R8	FILE PI-2094
			DRAWING NO. PI-2094	REV. A