

SIZE	A	B	C	D	AWWA C111/ANSI A21.11			WGT
					F	G	H	
24"	42	19.7	25.4	1	0	16	3/8	1,920
30"	51	22.7	29.5	1 1/4	8	12	1 1/4	3,720
36"	60	26.6	35.6	1 1/2	8	16	1 1/4	5,875
42"	72	30.7	41.0	1 1/2	8	20	1 1/4	9,500
48"	84	37.4	49.9	1 1/2	8	24	1 1/4	15,450

PRESSURE DATA, PER AWWA C517		
DESIGN PRESSURE RATING		150 PSI
TEST PRESSURE	SHELL TEST	225 PSI
	SEAT TEST (DIRECT)	150 PSI
	SEAT TEST (REVERSE)	100 PSI

ITEM	NAME	STANDARD MATERIAL
1	BODY	DUCTILE IRON
2	PLUG	DUCTILE IRON/BUNA-N
3	COVER	DUCTILE IRON
4	COVER BOLTS	316 STAINLESS STEEL
5	O-RING	BUNA-N
6	ADAPTER	DUCTILE IRON
7	UPPER THRUST WASHER	ALUMINUM BRONZE
8	UPPER GRIT EXCLUDER	BUNA-N
9	UPPER SHAFT BEARING	316 STAINLESS STEEL
10	V-PACKING	BUNA-N
11	GLAND	DUCTILE IRON
12	GLAND FASTENERS	304 STAINLESS STEEL
13	BOTTOM COVER	DUCTILE IRON
14	BOTTOM COVER O-RING	BUNA-N
15	BOTTOM COVER BOLTS	316 STAINLESS STEEL
16	LOWER SHAFT BEARING	316 STAINLESS STEEL
17	LOWER GRIT EXCLUDER	BUNA-N
18	LOWER THRUST WASHER	ALUMINUM BRONZE
19	PIPE PLUG	304 STAINLESS STEEL

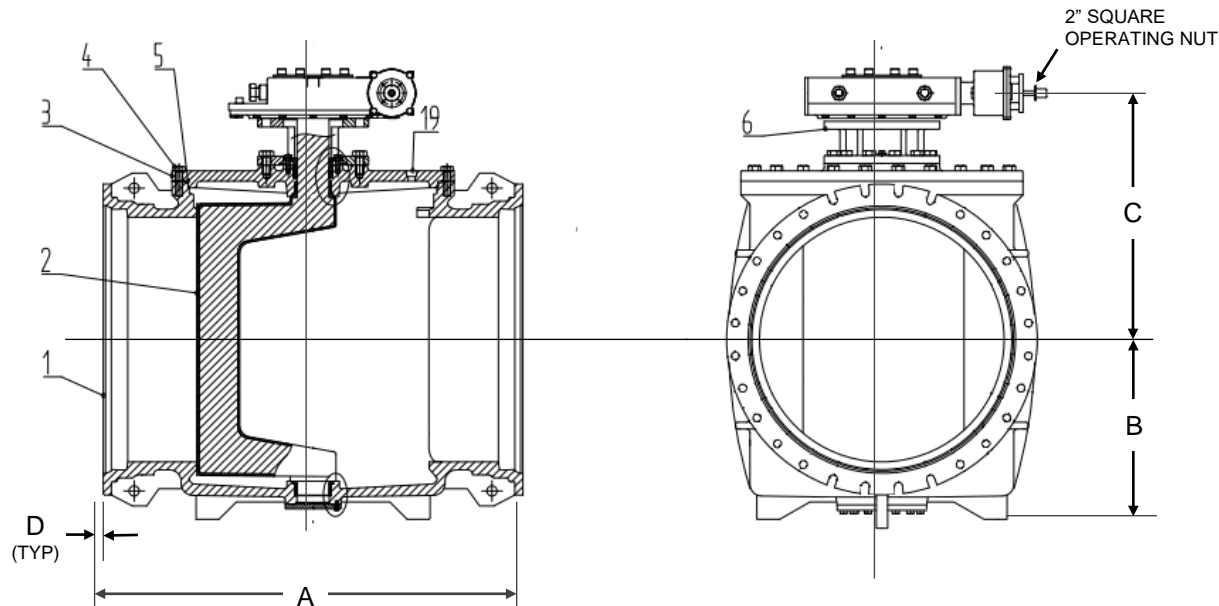

F = NUMBER OF SLOTS PER FLANGE
G = NUMBER OF HOLES PER FLANGE
H = WIDTH/DIAMETER OF SLOTS/HOLES

NOTES

- DESIGN STANDARD AWWA C517
- FLANGE DRILLING PER AWWA C111/ANSI A21.11
- DIMENSIONS AND WEIGHT ARE FOR STANDARD WORM GEAR ACTUATOR WITH HANDWHEEL
- DIMENSIONS IN INCHES, WEIGHT IN POUNDS AND ARE APPROXIMATE. REQUEST CERTIFIED DRAWINGS IF CRITICAL.

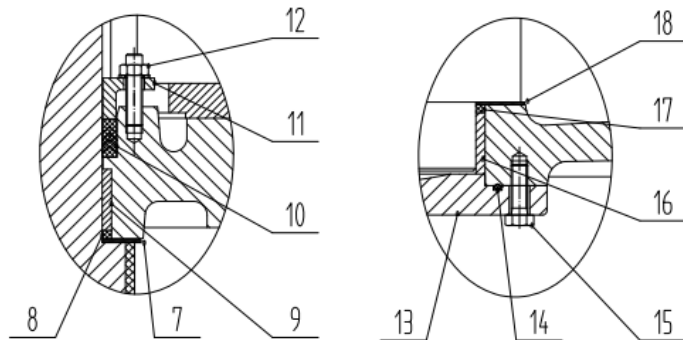

UPGRADED STANDARD FASTENERS TO 316SS	6-18-24	WJN
DESCRIPTION	DATE	BY

GA INDUSTRIES, a VAG Group Brand				
STANDARD PORT MECHANICAL JOINT ECCENTRIC PLUG VALVE WITH BURIED SERVICE WORM GEAR AND 2" NUT				
STANDARD TOLERANCES (UNLESS OTHERWISE NOTED) FINISHED SURFACES ONLY X = +/- 0.02" .XX = +/- 0.01" .XXX = +/- 0.002" FRACTIONS +/- 1/64" ANGLES +/- 1°	SERIAL NO.	SCALE NONE	DRAWN BY WJN APPR. BY	
	REFERENCES	EFFECTIVE DATE 1-1-2024 TO	FIG. NUMBER B517R8	REV. A