

SIZE	A	B	C	D	AWWA C111/ANSI A21.11			WGT
					F	G	H	
24"	42	20.7	28.0	1.0	0	18	7/8	2,510
30"	51	26.7	35.2	1.3	8	12	1 1/8	4,975
36"	60	30.7	40.1	1.5	8	16	1 1/8	7,775
42"	72	37.4	50.0	1.5	8	20	1 1/8	14,175
48"	84	42.3	54.7	1.5	8	24	1 1/8	20,145

PRESSURE DATA, PER AWWA C517		
DESIGN PRESSURE RATING		150 PSI
TEST PRESSURE	SHELL TEST	225 PSI
	SEAT TEST (DIRECT)	150 PSI
	SEAT TEST (REVERSE)	100 PSI

ITEM	NAME	STANDARD MATERIAL
1	BODY	DUCTILE IRON
2	PLUG	DUCTILE IRON/BUNA-N
3	COVER (BONNET)	DUCTILE IRON
4	COVER BOLTS	316 STAINLESS STEEL
5	O-RING	BUNA-N
6	ADAPTER	DUCTILE IRON
7	UPPER THRUST WASHER	ALUMINUM BRONZE
8	UPPER GRIT EXCLUDER	BUNA-N
9	UPPER SHAFT BEARING	316 STAINLESS STEEL
10	V-PACKING	BUNA-N
11	GLAND	DUCTILE IRON
12	GLAND FASTENERS	316 STAINLESS STEEL
13	BOTTOM COVER	DUCTILE IRON
14	BOTTOM COVER O-RING	BUNA-N
15	BOTTOM COVER BOLTS	316 STAINLESS STEEL
16	LOWER SHAFT BEARING	316 STAINLESS STEEL
17	LOWER GRIT EXCLUDER	BUNA-N
18	LOWER THRUST WASHER	ALUMINUM BRONZE
19	PIPE PLUG	304 STAINLESS STEEL

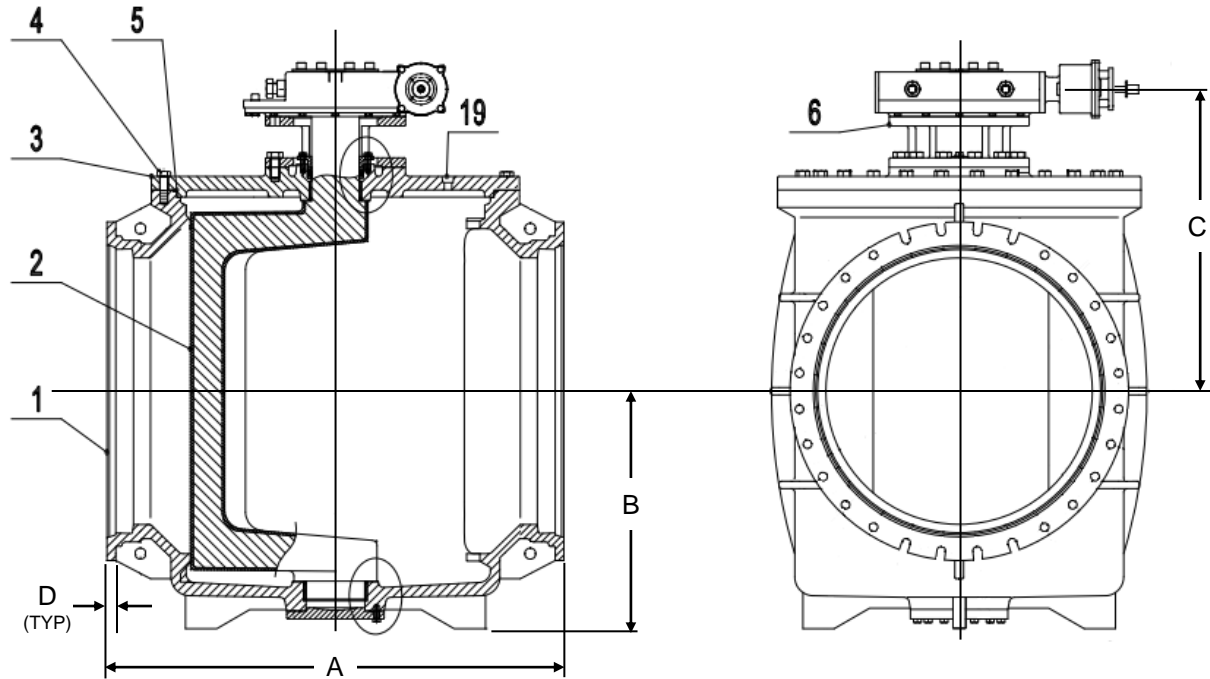

F – NUMBER OF SLOTS PER FLANGE  
 G – NUMBER OF HOLES PER FLANGE  
 H – WIDTH/DIAMETER OF SLOTS/HOLES

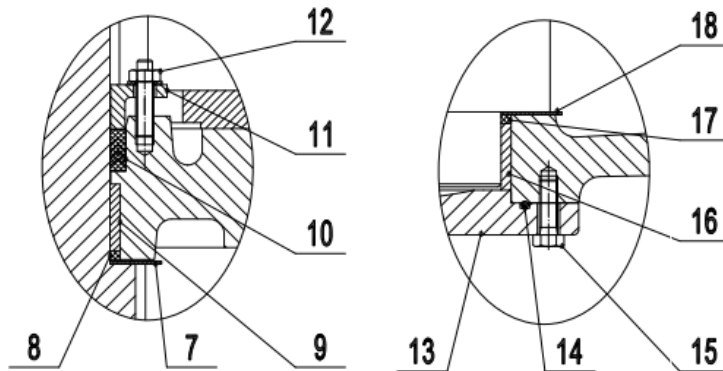

**NOTES**

- DESIGN STANDARD AWWA C517
- FLANGE DRILLING PER AWWA C111/ANSI A21.11
- DIMENSIONS AND WEIGHT ARE FOR STANDARD BURIED SERVICE WORM GEAR ACTUATOR 2" NUT
- DIMENSIONS IN INCHES, WEIGHT IN POUNDS AND ARE APPROXIMATE. REQUEST CERTIFIED DRAWINGS IF CRITICAL.

**GA INDUSTRIES, a VAG Group Brand**

100% PORT MECHANICAL JOINT ECCENTRIC PLUG VALVE WITH BURIED SERVICE WORM GEAR AND 2" NUT

STANDARD TOLERANCES (UNLESS OTHERWISE NOTED) FINISHED SURFACES ONLY .X = +0.02" .XX = +0.01" .XXX = +0.002" FRACTIONS +/- 1/64" ANGLES +/- 1°	SERIAL NO.	SCALE NONE	DRAWN BY WJN	
	REFERENCES	EFFECTIVE DATE 1-1-2024 TO	APPR. BY	
	FIG. NUMBER B517RF	FILE	DRAWING NO. PL-2097	REV. A

UPGRADED FASTENERS TO 316SS	6-18-24	WJN
DESCRIPTION	DATE	BY